



IRWIN® Rafter Square Reference Guide

**Complete Instruction Book and
Rafter Length Tables**

**Guide de référence pour l'équerre
de charpente IRWIN®**

**Manuel d'instructions complet et
tableaux des longueurs de chevrons**

**Guía de referencia IRWIN®
para escuadras de viga**

**Manual de instrucciones completo
y tabla de longitud de vigas**

IRWIN® RAFTER SQUARE REFERENCE GUIDE

Professional tradesmen use Rafter and Framing Squares to save time on roof construction projects. All of the necessary cuts for a particular rafter can be laid out with these two squares. This reference guide will provide a basic knowledge of rafters and the rafter square to help you determine what scale and number on the square to use, as well as all necessary tables for reference.

CONTENTS

Diagram of Rafter Square.	2
Types of Rafters	3
Using the Rafter Square.	6
Common Rafters.	9
Common Rafter Layout	10
Hip and Valley Rafters	13
Hip Rafter Layout	15
Valley Rafter Layout	17
Jack Rafters	19
Jack Rafter Layout	21
Dormer Rafters.	22
Degree Scale.	23
Rafter Length Tables.	24

DIAGRAM OF RAFTER SQUARE

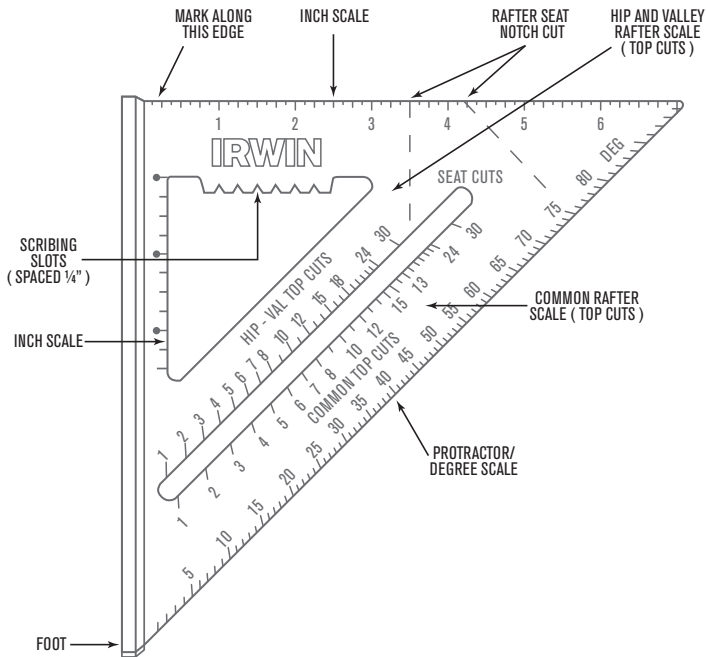

[Diagram 1 - IRWIN Rafter Square]

TYPES OF RAFTERS

Common Rafter: A rafter that runs perpendicular (90°) from the top of the wall plate to the roof ridge; its length forms the hypotenuse or diagonal of a right (90°) triangle, with the rise and run forming the right angle

Valley Rafter: A rafter that runs from the top of the wall plate to the roof ridge at the intersection of the gable extension with the main roof

Valley Jack Rafter: A rafter that runs from a valley rafter to the roof ridge, perpendicular to the ridge

Hip Rafter: A rafter that runs diagonally from the top of the wall plate to the roof ridge, forming the outside corner of the roof

Hip Jack Rafter: A rafter that runs from the top of the wall plate to the hip rafter, perpendicular to the wall plate

Cripple Jack Rafter: A rafter that runs from a hip rafter to a valley rafter, perpendicular to the roof ridge

Dormer Rafter: A rafter that sits on top of the main roof without cutting into the main roof. (For example, this rafter would be used when remodeling or adding on to an existing structure.)

Figures 1 and 2 on the next page show each type of rafter.

[Fig. 1 - Types of Rafters - 3D]

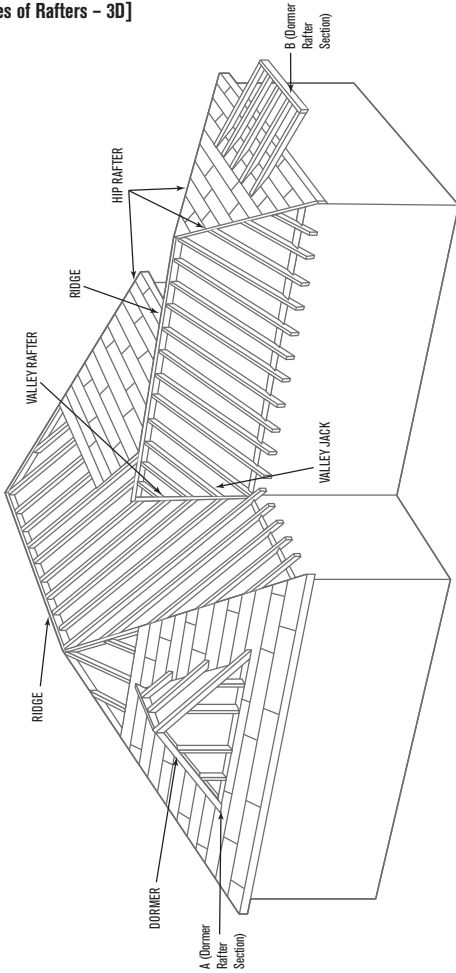

All cuts on this roof can be made by using the appropriate inch rise number on the rafter square.

[Fig. 2 - Types of Rafters - Top View]

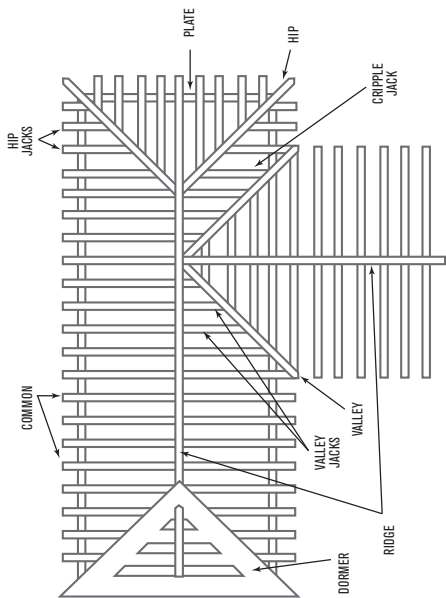

USING THE RAFTER SQUARE

The use of the Rafter Square is based on two simple building measurements: (1) the rafter run and (2) the rafter rise. These can be obtained from building blueprints, drawings, or actual measurements. The tables included in this reference guide are based on these two simple measurements.

(See figure 3.)

Rafter Run: The horizontal distance that the rafter will span, measured in feet

Rafter Rise: The vertical distance between the highest and lowest point of the rafter, measured in feet

Inch Rise: The rise measured in inches per foot run

The Inch Rise gives you the corresponding scale number to use on the square and is calculated as follows. Inch Rise, run, and the tables in the back of this guide are all that you need to layout rafter lengths and cuts for common, hip, valley, and jack rafters.

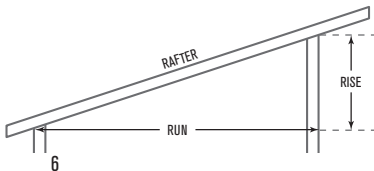
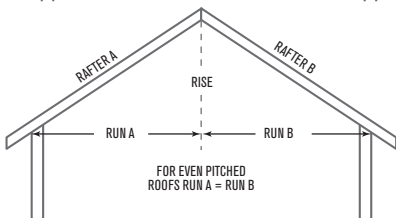
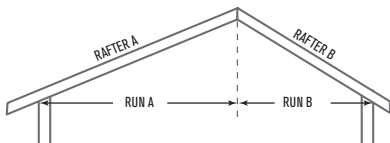
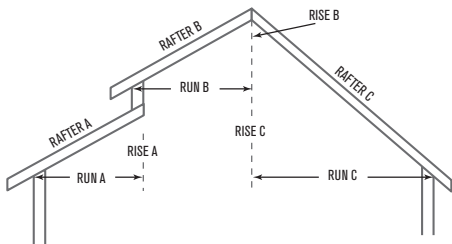

[Fig. 3 - Rafter Rise and Run]

$$\frac{\text{INCH RISE}}{\text{(SCALE NUMBER)}} = \frac{\text{RAFTER RISE (ft)} \times 12}{\text{RAFTER RUN (ft)}}$$

The procedure for basic roof construction is as follows (*See figure 4.*):

- 1. Obtain Rafter Run:** Measure or calculate the horizontal distance the rafter will span, starting at the outside of the wall on which it rests and including any boarding on the wall if it extends to the wall top plate.
- 2. Obtain Roof Rise:** Measure, calculate, or obtain from the blueprints the distance in feet the ridge will be from the top of the wall.

Use the following table to convert inches to feet:

Convert Inches to Feet

1" = .08'	4" = .33'	7" = .58'	10" = .83'
2" = .16'	5" = .42'	8" = .67'	11" = .92'
3" = .25'	6" = .50'	9" = .75'	

- 3. Calculate Inch Rise:** Using the table above, convert rise to feet in decimal form and calculate using the Inch Rise Formula.

EXAMPLE: Run = 15'; Rise = 8'8" or 8.67'

$$\frac{8.67 \text{ (ft)} \times 12}{15 \text{ (ft)}} = 6.94 \text{ in/ft. Run}$$

You may round off Inch Rise to the nearest inch, which can make the actual roof rise slightly higher or lower but will not matter in most cases. If the Inch Rise is provided on a blueprint, the previous calculation is not needed.

With the Inch Rise calculated, we are now ready to layout each type of rafter.

[Fig. 4 - The Common Rafter]

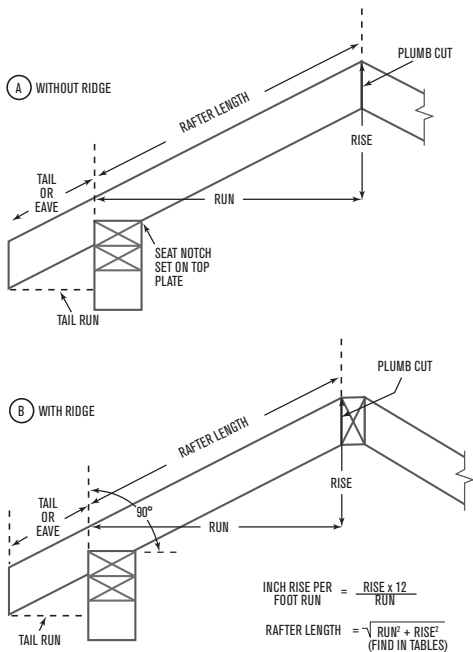

COMMON RAFTERS

Common Rafter Length: Once Inch Rise and Run are calculated, use the tables in the back of this book to find common rafter length. NOTE: For a run greater than that given in the tables, add any two runs that will equal the desired run, then find the respective lengths for those two rafters and add them together.

EXAMPLE: Using the 7 Inch Rise table (and our 15' run), the common rafter length is 17' 4 $\frac{3}{8}$ ". This is the rafter length from the top cut to the seat plumb mark.

Tail or Eave Length: The tail or eave overhang must be added to the rafter length. *(See figure 5 for various eave constructions.)*

EXAMPLE: With a tail run of 1' 8", use the same 7 Inch Rise table, under Common Rafter Length:

$$1' \text{ Run} = 1' 1\frac{7}{8}"$$

$$8" \text{ Run} = 9\frac{1}{4}"$$

$$1' 8" \text{ Tail} = 1' 11\frac{1}{8}"$$

Common Rafter Lumber Length: To obtain the total lumber length required, an allowance for the bottom plumb cut must be added. *(See figure 6.)* This allowance can be obtained by using the tables as well.

EXAMPLE: Using the 7 Inch Rise page and assuming 2 x 6 lumber (which has a depth of 5 $\frac{1}{2}$ "), use the Rafter Depth and Bottom Allowance table to see that the common and jack allowance equals 3 $\frac{3}{16}$ " inches. The total lumber length required for this common rafter is:

$$\text{RAFTER LENGTH} = 17' 4\frac{3}{8}"$$

$$\text{TAIL LENGTH} = 1' 11\frac{1}{8}"$$

$$\text{BOTTOM ALLOWANCE} = 3\frac{3}{16}"$$

$$\text{TOTAL LUMBER LENGTH} = 19' 6\frac{11}{16}"$$

Common Rafter Layout

1. Top Plumb Cut: If the lumber is not straight, always put the high or crown side up. At the top of the rafter, place the rafter square on the face of the rafter as in figure 7. Pivot the layout square so that the number 7 on the common scale lines up with the edge of the rafter. Starting at the pivot point along the top edge of the square, mark your line while holding the pivot point firmly against the rafter and keeping the number 7 lined up properly. This will be the top plumb cut.

2. Seat Notch or Birds Mouth:

Using the rafter length (our example: 17' 4 $\frac{3}{8}$ "), measure down the top of the rafter and mark another plumb mark the same as in Step 1. This line represents the outside wall of your building. From this point, there are two alternatives to marking the seat notch:

- a. **Varying horizontal seat cut length.** As shown in figure 8a, line up the dash line at 4 $\frac{1}{4}$ " on the square with the plumb mark and make a horizontal line, which will be perpendicular to

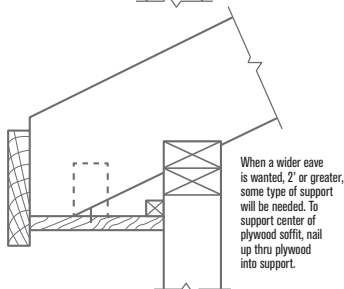
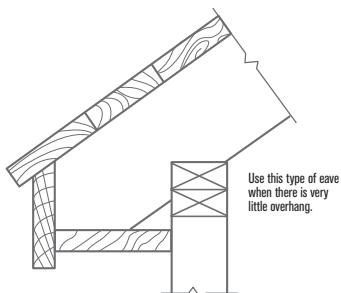
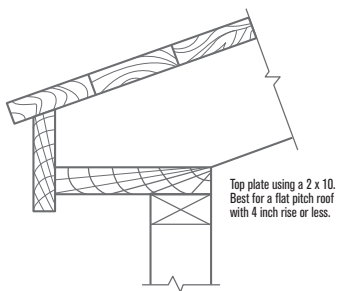

[Fig. 5 - Eave Constructions]

the plumb mark. Make all seat notches the same depth and never notch more than halfway through the rafter.

- b. $3\frac{1}{2}$ " horizontal seat cut length. As shown in figure 8b, placing the pivot of the square against the outside of the rafter, line up the dash line at $3\frac{1}{2}$ " on the square with the plumb mark and make the horizontal line.

3. Tail or Bottom Plumb Cut: Using the tail length (our example: $1' 11\frac{3}{8}"$), measure down the rafter from the seat plumb mark and make the bottom plumb mark the same as in Step 1. If the mark is too close to the end of the lumber, turn the square over to the bottom edge of the rafter, and still using the number 7, make the bottom plumb mark. You may wish to leave the tails long and make the bottom plumb cuts after all the rafters are set.

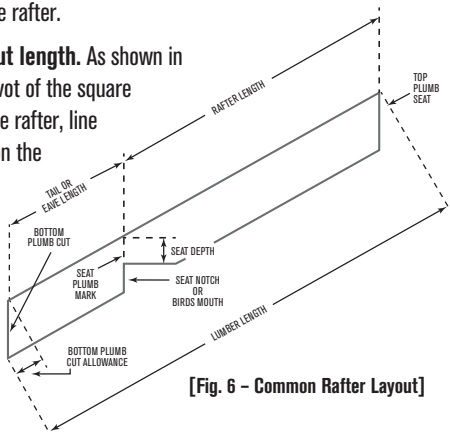

[Fig. 6 - Common Rafter Layout]

[Fig. 7 - Top Plumb Cut of a Common Rafter]

Drawing shows square in position for marking top plumb cut of a common rafter with a 7" rise, or $30\frac{1}{4}^\circ$.

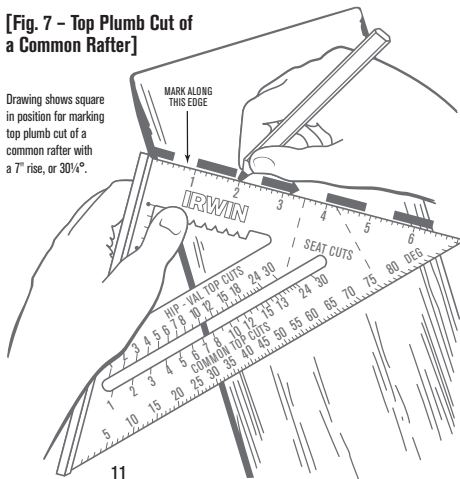

**[Fig. 8a – Seat Notch Layout
(varying seat cut length)]**

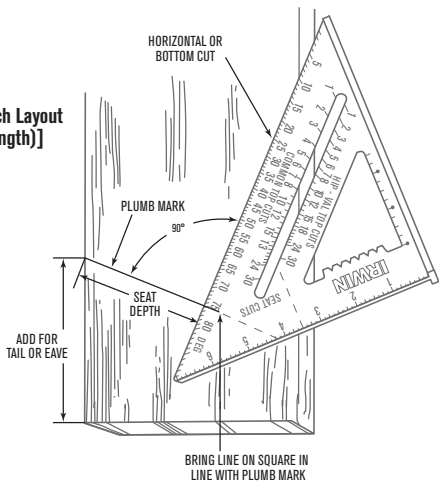

**[Fig. 8b – Seat Notch Layout
(3½" seat cut length)]**

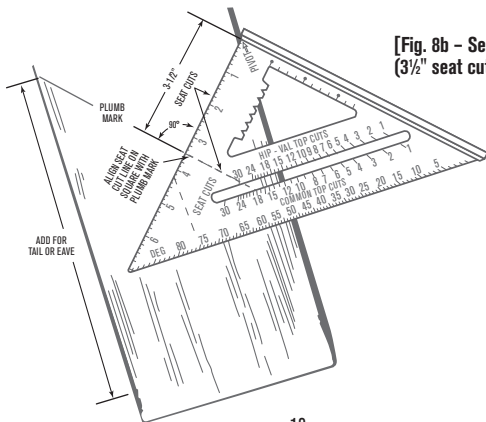

HIP AND VALLEY RAFTERS

Because hip and valley rafters both run at a 45° angle to the common rafter, they are treated very similarly, and the cuts and lengths apply equally to both types of rafters. *(See figure 2.)*

Hip-Val Length: Using the tables, obtain the hip or valley rafter length.

EXAMPLE: For our example (7 inch Rise, 15' run), the hip or valley rafter length is 22' 11³/₈".

[Fig. 9 - Top View of Hip Rafter Layout]

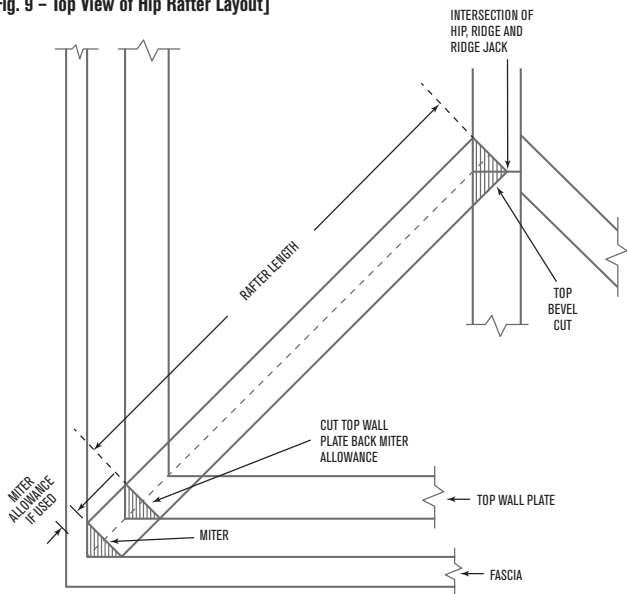

[Fig. 10 - Hip Rafter Layout]

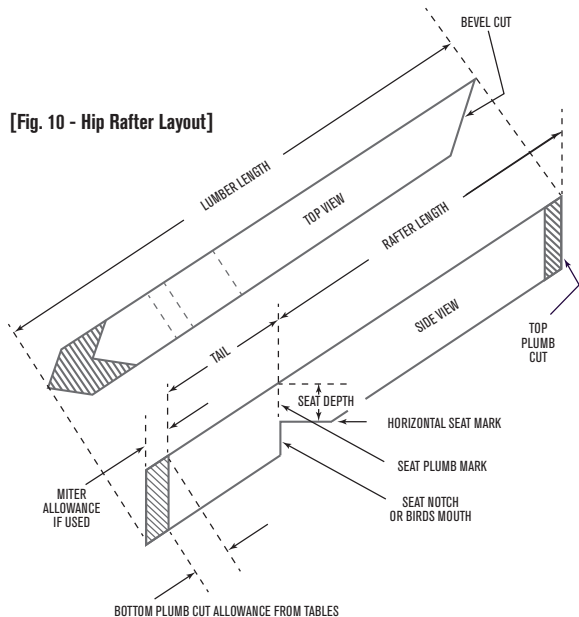

Tail or Eave Length: Use the same procedure as that for the common rafters, taking care to use the Hip-Val column in the tables instead.

EXAMPLE: With a tail run of 1' 8", use the same 7 Inch Rise table, under Hip or Val Rafter Length:

$$1' \text{ Run} = 1' 6\frac{3}{8}"$$

$$8" \text{ Run} = 12\frac{1}{8}"$$

$$1' 8" \text{ Tail} = 2' 6\frac{1}{2}"$$

NOTE: If miter is desired, add the miter allowance from the tables. (*See figures 9 and 10.*)

Hip-Val Lumber Length: To the above determined lengths, add an allowance for the bottom plumb cut as well as the miter allowance if used, to get the overall lumber length.

EXAMPLE: Assuming a 2 x 6 again and a miter allowance using a 1½" rafter thickness:

RAFTER LENGTH	=	22' 11 ³ / ₈ "
TAIL LENGTH	=	2' 6 ¹ / ₂ "
BOTTOM PLUMB ALLOWANCE	=	3 ³ / ₁₆ "
MITER ALLOWANCE	=	7 ¹ / ₈ "
<hr/>		
LUMBER LENGTH	=	25' 9 ¹⁵ / ₁₆ "

NOTE: Only add miter allowance if miter is used.

Hip Rafter Layout

- 1. Top Plumb Cut:** Use the square in the same manner as in Step 1 of the common rafter top plumb cut, except using the Hip-Val scale. Make the top plumb cut mark. (*See figure 10.*) Because the top plumb cut is a bevel cut and opposite rafters will have opposite bevel cuts, be sure to make the mark on the side of the rafter which will be the long side of the bevel. The bevel cut will be explained in Step 4.
- 2. Seat Notch:** Measure the rafter length (our example: 22' 11³/₈") down the top of the rafter and make the seat plumb mark in the same manner as the top plumb mark in Step 1. Using either "Rafter Seat Cut" dashed line on the square, make the horizontal seat mark in the same manner as with the common rafter. (*See figures 8a and 8b.*) For proper fit of the hip rafter, cut the top wall plate corner off as shown in figure 9. This will allow the hip seat notch to set in against a full flat corner.

3. **Tail or Bottom Plumb Cut:** Measure down the top of the hip rafter from the seat plumb mark and mark the distance for the tail (our example: 2' 6½"). Using the rafter square, make the bottom plumb mark at this point. If a tail miter is used, make another plumb mark on the other side of the rafter. *(See figure 10.)*
4. **Hip Rafter Pattern Cuts:** With your saw set at 45°, cut the top plumb cut, making sure the top bevels are opposite for opposite rafters. Setting the saw at 45° automatically gives the plumb cut and side cut bevel. If miter is used, make the bottom plumb cut on a 45° angle as well. If miter is not used, set the saw at 90°. The seat notch is made with the saw set at 90°. *(See figure 10.)*

Intersection of Hips on Ridge

To find the intersection points of the hip on the ridge rafter, cut the ridge rafter one foot longer at the point where the hips intersect with the ridge. Using a regular length common rafter, set the seat notch cut over the edge of the top plate, in line

[Fig. 11 – Intersection of Hips on Ridge]

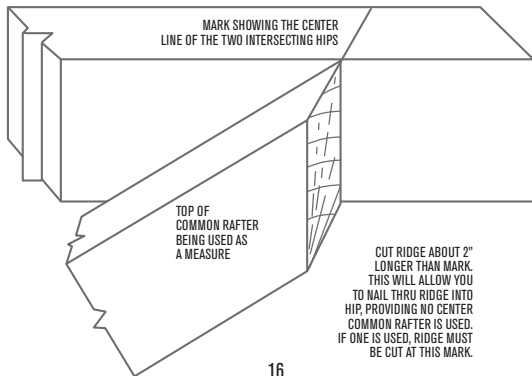

with the ridge. Be sure your walls are straight. Place the top end of the common rafter even with the top of the ridge. **(See figure 11.)** Mark across the ridge as shown. This mark will be the center of the two intersecting hips. If a common rafter is to be used, the ridge will be cut off at this mark and the common rafter butted up against it. If no common rafter is used, cut the ridge about 2" longer. This will allow you to nail through the ridge into the hip.

Valley Rafter Layout

- 1. Top Plumb Cut:** Using the Hip-Val scale on the square, follow the same method we've been using for the top plumb mark. Measure down the top of the rafter from this mark for the miter allowance (if used) obtained from the tables (our example: $\frac{7}{8}$ "). Make another plumb mark on both sides of the rafter. **(See figure 13.)** Be sure to use the Hip-Val scale and the length and allowance from the Hip-Val column in the tables.
- 2. Seat Notch:** From the first top plumb mark, measure down the valley rafter length (Our example: 22' 11 $\frac{3}{8}$ ") and make the seat plumb mark. **(See figures 12 and 13.)** Move down the rafter from this mark the miter allowance distance and make another plumb mark. For the horizontal seat notch line, measure down to the seat depth on the FIRST plumb mark. Extend the horizontal line to the added miter allowance line using the dash line on the square. **(See figures 12 and 13.)** All seat notches must be the same depth.
- 3. Bottom or Tail Plumb Cut:** Measure down the top of the rafter from the FIRST seat plumb mark and mark the tail length (our example: 2' 6 $\frac{1}{2}$ "). Make the bottom plumb mark with the square. Add the miter allowance in the measurement, if used. **(See figure 13.)**

[Fig. 12 - Top View of Valley Rafter Layout]

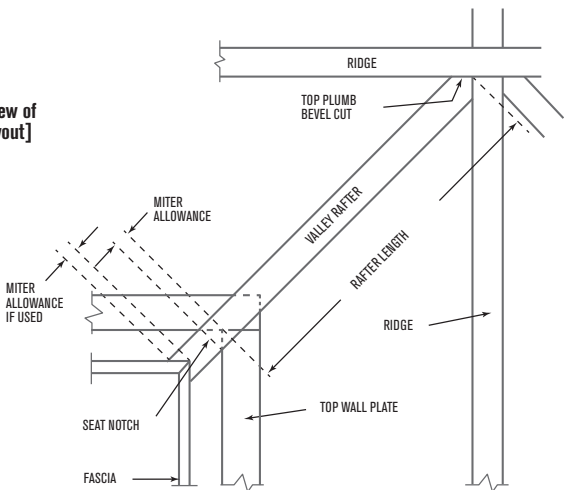

[Fig. 13 - Valley Rafter Layout]

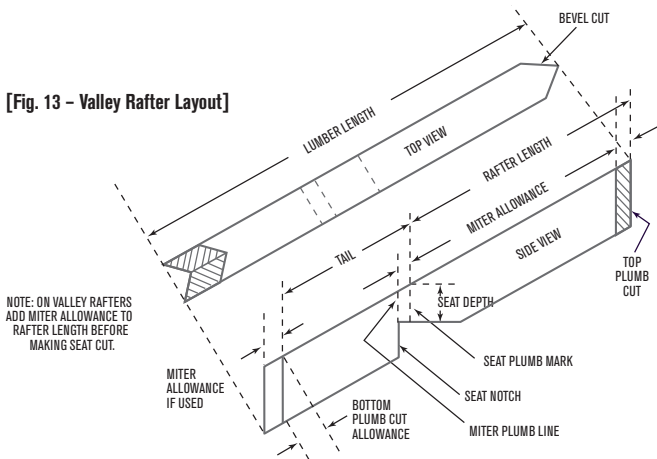

NOTE: ON VALLEY RAFTERS
ADD MITER ALLOWANCE TO
RAFTER LENGTH BEFORE
MAKING SEAT CUT.

4. **Valley Rafter Pattern Cuts:** Set the saw at 45° to make the top and bottom cuts as in figure 13. Also, make the seat miter cuts with the 45° setting. Change to 90° for the horizontal seat notch.

JACK RAFTERS

Jack Rafter Length: The jack rafter tables are different than the other rafter tables. The first column in the table lists the varying center to center spacing of jack rafters. The second column is the difference in length from one jack to the next. (*See figures 14 and 15.*) This difference in length is to be added or subtracted from the rafter length as you move from jack to jack.

EXAMPLE: For a 7 Inch Rise and assuming 24" rafter spacing, the amount to add or subtract is $2' 3\frac{3}{4}"$.

To obtain the length of the first or longest jack, measure the distance from the edge of the last common rafter to the intersection of the hip and ridge, for a hip jack, or the valley and top plate, for a valley jack. Subtract this measurement (D) from the spacing you are using (S) to get the distance from the intersection to the first jack (S-D). Use the table for this distance and find the length to subtract from a common rafter length. This gives you the rafter length for the first or longest jack. (*See figures 14 and 15.*)

EXAMPLE: Rafter spacing (S) is 24"; the distance from common rafter to intersection (D) = 12"; (S-D) = 12". From the 7 Inch Rise table, we have a length of $1' 1\frac{7}{8}"$. Therefore:

COMMON RAFTER	=	$17' 4\frac{3}{8}"$
SUBTRACT	-	$1' 1\frac{7}{8}"$
<hr/>		
FIRST JACK RAFTER LENGTH	=	$16' 2\frac{1}{2}"$

Remember to add tail length to this length. For all remaining jacks, subtract the full spacing (S). Example: S = 24" jack length subtracted = 2' 3³/₄" from the tables. Therefore:

$$\begin{array}{r} \text{FIRST JACK RAFTER LENGTH} = 16' 2\frac{1}{2}'' \\ \text{SUBTRACT} \quad \quad \quad \quad - 2' 3\frac{3}{4}'' \\ \hline \text{SECOND JACK RAFTER LENGTH} = 13' 10\frac{3}{4}'' \end{array}$$

Continue this process to the last jack rafter (note that this procedure is the same for hip jacks and valley jacks). Be sure to measure jack rafter length on the long side of the rafter because of the bevel. Cripple jacks use the same method but must be beveled on both ends; therefore, the subtraction for both ends must be made from a common rafter length as if it went from the plate to the ridge. (*See figure 2.*)

Tail or Eave Length: The tail length for all jack rafters resting on the wall plate is the same as for common rafters. Valley jacks and cripple jacks have no tail. (*See figures 14 and 15.*)

Lumber Length: Lumber length is found by using the same procedure outlined for common rafters: jack rafter length + tail length + bottom allowance, then subtracting for the rafters position per above.

Jack Rafter Layout

Bottom plumb cuts and seat notches for all jack rafters resting on the wall plate are the same as for common rafters. The common scale is used for all jack rafters. Where jack rafters rest against a hip or valley, mark a plumb cut, then cut at a 45° angle along the mark. This will give both the plumb cut and the side cut. See figures 11 and 14 for the center common rafter at the end of the ridge.

DORMER RAFTERS

When remodeling or adding a room, it is sometimes easier to build a valley on top of the main roof. This saves cutting into the main roof which could cause weakening.

- 1. Mark Location of the Valley on the Roof at 45° to the Common Rafters.**
(See figure 1.) Set the long point of the bottom end of the rafter even with line A.
- 2. Plumb Cuts on the Dormer Rafter:** These will be done the same as the common rafter, using the appropriate Inch Rise.
- 3. Rafter Length:** After measuring the shortest rafter, length may be determined by using the same method as with jack rafters.
- 4. Bottom Cut:** This is a horizontal cut as in Figure 8. Do not cut on the plumb mark; rather, cut horizontally all the way across the rafter. Before making the horizontal cut, tilt the base of your saw at the same angle as the rise of your roof to allow your horizontal cut to lay flat against your roof.

EXAMPLE: Using the common rafter scale on the square and the 7 Inch Rise, you will notice that the number 7 lines up with 30° on the degree scale below. Therefore, tilt your saw at 30° .

Figure 1 also shows a roof that is sometimes used over doors. To find the end cut at point B, hold the square so that the T-bar is flat against the rafter for the plumb cut of a flat roof. Using the common rafter scale, mark the pivot point and make a mark at the rising using the same rise as the main roof. Then mark a line through these two points. This is the cut required.

DEGREE SCALE

The degree scale on the rafter square can be used to mark any angle cut across a board. (*See figure 16.*) Place the pivot point on the mark where the cut is to be made on the board. Set the degree scale on the edge of the board at the required angle and mark a line along the top edge as shown in the figure.

EXAMPLE: To find an obtuse angle of 120° , place the pivot on the mark where the cut is to be made and hold the square T-bar tight against the board. Mark the 90° line across the board. Flip the square on its opposite side, holding it at the same pivot point, and pivot it so that the degree scale reads 30° ($120^\circ - 90^\circ$). Marking a line along the bottom edge of the square gives you a 120° angle (as well as a 30° and 60°).

[Fig. 16 - Angles Using the Degree Scale]

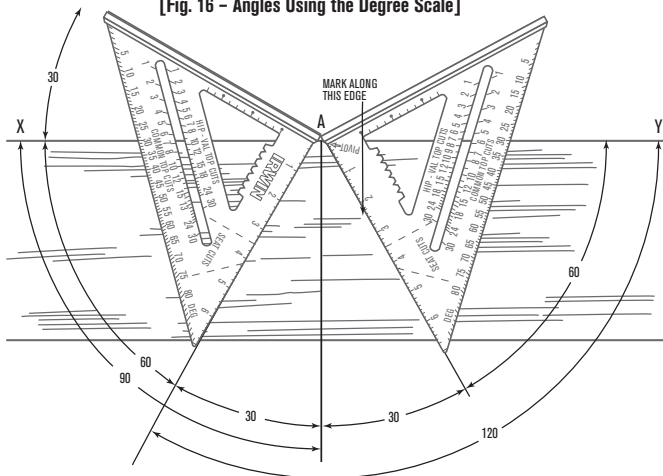

Square shown in 2 different positions with the resulting angles being found by pivoting square at point A on line X-Y.

Lay square with foot horizontal on X-Y line to find 90° .

1 INCH RISE 1-12 PITCH 4³/₄ DEGREES

Run Ft.	Common Rafter Length	Hip or Val. Rafter Length
1	1' 0 ¹ / ₁₆ "	1' 5"
2	2' 0 ⁰ / ₈ "	2' 10"
3	3' 0 ⁰ / ₈ "	4' 3"
4	4' 0 ⁰ / ₈ "	5' 8"
5	5' 0 ⁰ / ₄ "	7' 1"
6	6' 0 ⁰ / ₄ "	8' 6"
7	7' 0 ⁰ / ₄ "	9' 11"
8	8' 0 ³ / ₈ "	11' 4"
9	9' 0 ³ / ₈ "	12' 9"
10	10' 0 ³ / ₈ "	14' 2"
11	11' 0 ¹ / ₂ "	15' 7"
12	12' 0 ¹ / ₂ "	17' 0"
13	13' 0 ¹ / ₂ "	18' 5"
14	14' 0 ⁰ / ₈ "	19' 10"
15	15' 0 ⁰ / ₈ "	21' 3"
16	16' 0 ⁰ / ₈ "	22' 8"
17	17' 0 ⁰ / ₈ "	24' 1"
18	18' 0 ³ / ₄ "	25' 6"
19	19' 0 ³ / ₄ "	26' 11"
20	20' 0 ⁰ / ₈ "	28' 4"
21	21' 0 ⁰ / ₈ "	29' 9"
22	22' 0 ⁰ / ₈ "	31' 2"
23	23' 1"	32' 7"
24	24' 1"	34' 0"
25	25' 1"	35' 5"

Run In.	Common Rafter Length	Hip or Val. Rafter Length
½	½"	¾"
1	1"	1 ¹ / ₈ "
1½	1½"	2 ¹ / ₈ "
2	2"	2 ¹ / ₈ "
2½	2½"	3½"
3	3"	4¼"
3½	3½"	5"
4	4"	5 ⁵ / ₈ "
4½	4½"	6 ³ / ₈ "
5	5"	7 ¹ / ₈ "
5½	5½"	7¾"
6	6"	8½"
6½	6½"	9¼"
7	7"	9 ¹ / ₈ "
7½	7½"	10 ⁵ / ₈ "
8	8"	11 ¹ / ₈ "
8½	8½"	12"
9	9"	12¾"
9½	9½"	13½"
10	10"	14 ¹ / ₈ "
10½	10½"	14 ¹ / ₈ "
11	11"	15 ⁵ / ₈ "
11½	11½"	16¼"

Spacing In.	Jack Rafter Length
1	1"
2	2"
3	3"
4	4"
5	5"
6	6"
7	7"
8	8"
9	9"
10	10"
11	11"
12	1' 0"
13	1' 1"
14	1' 2"
15	1' 3"
16	1' 4"
17	1' 5"
18	1' 6 ¹ / ₈ "
19	1' 7 ¹ / ₈ "
20	1' 8 ¹ / ₈ "
21	1' 9 ¹ / ₈ "
22	1' 10 ¹ / ₈ "
23	1' 11 ¹ / ₈ "
24	2' 0 ⁰ / ₈ "

Rafter Thickness	Miter Allowance for Hip and Valley Rafters	Rafter Depth	Bottom Allowance
1½"	¾"	3½"	5 ¹ / ₁₆ "
1 ⁵ / ₈ "	1 ¹ / ₁₆ "	5½"	7 ¹ / ₁₆ "
1¾"	7 ¹ / ₈ "	7¼"	5 ¹ / ₈ "
1 ¹ / ₈ "	1 ⁵ / ₁₆ "	9¼"	¾"

2 INCH RISE 2-12 PITCH 9½ DEGREES

Run Ft.	Common Rafter Length	Hip or Val. Rafter Length
1	1' 0½"	1' 5½"
2	2' 0¾"	2' 10½"
3	3' 0½"	4' 3¼"
4	4' 0¾"	5' 8¾"
5	5' 0½"	7' 1½"
6	6' 1"	8' 6½"
7	7' 1½"	9' 11¾"
8	8' 1¾"	11' 4¾"
9	9' 1½"	12' 9¾"
10	10' 1¾"	14' 2¾"
11	11' 1¾"	15' 8"
12	12' 2"	17' 1"
13	13' 2½"	18' 6½"
14	14' 2¾"	19' 11¼"
15	15' 2½"	21' 4¾"
16	16' 2¾"	22' 9¾"
17	17' 2¾"	24' 2½"
18	18' 3"	25' 7¾"
19	19' 3½"	27' 0¾"
20	20' 3¾"	28' 5¼"
21	21' 3½"	29' 10⅛"
22	22' 3¾"	31' 3¾"
23	23' 3¾"	32' 9"
24	24' 4"	34' 2¾"
25	25' 4½"	35' 7¼"

Run In.	Common Rafter Length	Hip or Val. Rafter Length
½	½"	¾"
1	1"	1 ¾"
1½	1½"	2 ⅛"
2	2"	2 ⅞"
2½	2½"	3 ½"
3	3"	4 ¼"
3½	3½"	5"
4	4"	5 ¾"
4½	4¾"	6 ¾"
5	5"	7 ⅛"
5½	5½"	7 ⅞"
6	6"	8 ½"
6½	6¾"	9 ¼"
7	7"	9 ⅞"
7½	7½"	10 ⅝"
8	8"	11 ¾"
8½	8¾"	12"
9	9"	12 ¾"
9½	9½"	13 ½"
10	10"	14 ¼"
10½	10½"	14 ⅞"
11	11"	15 ⅝"
11½	11½"	16 ¾"

Spacing In.	Jack Rafter Length
1	1"
2	2"
3	3"
4	4"
5	5 ⅞"
6	6 ⅞"
7	7 ⅞"
8	8 ⅞"
9	9 ⅞"
10	10 ⅞"
11	11 ⅞"
12	1' 0 ⅞"
13	1' 1 ⅞"
14	1' 2 ¼"
15	1' 3 ¼"
16	1' 4 ¼"
17	1' 5 ¼"
18	1' 6 ¼"
19	1' 7 ¼"
20	1' 8 ¼"
21	1' 9 ¼"
22	1' 10 ¼"
23	1' 11 ¾"
24	2' 0 ¾"

Rafter Thickness	Miter Allowance for Hip and Valley Rafters	Rafter Depth	Bottom Allowance
1½"	¾"	3 ½"	⅞"
1¾"	13/16"	5 ½"	15/16"
1¾"	7/8"	7 ¼"	13/16"
1¾"	15/16"	9 ¼"	13/16"

3 INCH RISE 3-12 Pitch 14 Degrees

Run Ft.	Common Rafter Length	Hip or Val. Rafter Length
1	1' 0 ³ / ₈ "	1' 5 ¹ / ₄ "
2	2' 0 3/4"	2' 10 ¹ / ₂ "
3	3' 1 1/8"	4' 3 ³ / ₄ "
4	4' 1 1/2"	5' 8 ¹ / ₈ "
5	5' 1 7/8"	7' 2 ¹ / ₈ "
6	6' 2 1/4"	8' 7 ³ / ₈ "
7	7' 2 5/8"	10' 0 ⁵ / ₈ "
8	8' 3"	11' 5 ³ / ₈ "
9	9' 3 3/8"	12' 11 ¹ / ₈ "
10	10' 3 3/4"	14' 4 ³ / ₈ "
11	11' 4 1/8"	15' 9 ⁵ / ₈ "
12	12' 4 3/8"	17' 2 ³ / ₄ "
13	13' 4 3/4"	18' 8"
14	14' 5 1/8"	20' 1 ¹ / ₄ "
15	15' 5 1/2"	21' 6 ¹ / ₂ "
16	16' 5 5/8"	22' 11 ¹ / ₄ "
17	17' 6 1/4"	24' 5"
18	18' 6 5/8"	25' 10 ¹ / ₄ "
19	19' 7"	27' 3 ¹ / ₂ "
20	20' 7 3/8"	28' 8 ³ / ₈ "
21	21' 7 3/4"	30' 1 ¹ / ₈ "
22	22' 8 1/8"	31' 7 ¹ / ₈ "
23	23' 8 1/2"	33' 0 ³ / ₈ "
24	24' 8 3/8"	34' 5 ³ / ₈ "
25	25' 9 1/4"	35' 10 ³ / ₈ "

Run In.	Common Rafter Length	Hip or Val. Rafter Length
1/2	1/2"	3/4"
1	1"	1 1/8"
1 1/2	1 1/2"	2 1/8"
2	2"	2 7/8"
2 1/2	2 5/8"	3 5/8"
3	3 3/8"	4 1/4"
3 1/2	3 5/8"	5"
4	4 1/8"	5 3/4"
4 1/2	4 5/8"	6 1/2"
5	5 5/8"	7 1/8"
5 1/2	5 5/8"	7 7/8"
6	6 1/8"	8 5/8"
6 1/2	6 5/8"	9 3/8"
7	7 7/8"	10"
7 1/2	7 5/8"	10 3/4"
8	8 1/8"	11 1/2"
8 1/2	8 3/4"	12 1/4"
9	9 1/4"	12 7/8"
9 1/2	9 3/4"	13 5/8"
10	10 1/4"	14 3/8"
10 1/2	10 3/4"	15 1/8"
11	11 1/4"	15 3/4"
11 1/2	11 3/4"	16 1/2"

Spacing In.	Jack Rafter Length
1	1"
2	2"
3	3 3/8"
4	4 1/8"
5	5 5/8"
6	6 1/8"
7	7 1/4"
8	8 1/4"
9	9 1/4"
10	10 1/4"
11	11 3/8"
12	1' 0 3/8"
13	1' 1 3/8"
14	1' 2 3/8"
15	1' 3 1/2"
16	1' 4 1/2"
17	1' 5 1/2"
18	1' 6 1/2"
19	1' 7 3/8"
20	1' 8 3/8"
21	1' 9 5/8"
22	1' 10 5/8"
23	1' 11 3/4"
24	2' 0 3/4"

Rafter Thickness	Miter Allowance for Hip and Valley Rafters	Rafter Depth	Bottom Allowance
1 1/2"	3/4"	3 1/2"	7/8"
1 5/8"	13/16"	5 1/2"	1 3/8"
1 3/4"	7/8"	7 1/4"	1 13/16"
1 7/8"	15/16"	9 1/4"	2 3/16"

4 INCH RISE 4-12 PITCH 18½ DEGREES

Run Ft.	Common Rafter Length	Hip or Val. Rafter Length
1	1' 0 ⁵ / ₈ "	1' 5 ³ / ₈ "
2	2' 1 ¹ / ₄ "	2' 10 ⁷ / ₈ "
3	3' 2"	4' 4 ¹ / ₄ "
4	4' 2 ⁵ / ₈ "	5' 9 ³ / ₄ "
5	5' 3 ¹ / ₄ "	7' 3 ¹ / ₈ "
6	6' 3 ³ / ₈ "	8' 8 ⁵ / ₈ "
7	7' 4 ¹ / ₂ "	10' 2"
8	8' 5 ¹ / ₄ "	11' 7 ¹ / ₂ "
9	9' 5 ⁵ / ₈ "	13' 0 ⁷ / ₈ "
10	10' 6 ¹ / ₂ "	14' 6 ³ / ₈ "
11	11' 7 ¹ / ₈ "	15' 11 ³ / ₄ "
12	12' 7 ³ / ₄ "	17' 5 ¹ / ₄ "
13	13' 8 ¹ / ₂ "	18' 10 ⁵ / ₈ "
14	14' 9 ¹ / ₈ "	20' 4 ¹ / ₈ "
15	15' 9 ³ / ₄ "	21' 9 ¹ / ₂ "
16	16' 10 ³ / ₈ "	23' 3"
17	17' 11"	24' 8 ³ / ₈ "
18	18' 11 ⁵ / ₈ "	26' 1 ¹ / ₈ "
19	20' 0 ³ / ₈ "	27' 7 ¹ / ₄ "
20	21' 1"	29' 0 ³ / ₄ "
21	22' 1 ⁵ / ₈ "	30' 6 ¹ / ₈ "
22	23' 2 ¹ / ₄ "	31' 11 ⁵ / ₈ "
23	24' 3"	33' 5"
24	25' 3 ³ / ₈ "	34' 10 ¹ / ₂ "
25	26' 4 ¹ / ₄ "	36' 3 ³ / ₈ "

Run In.	Common Rafter Length	Hip or Val. Rafter Length
½	½"	¾"
1	1"	1½"
1½	1½"	2½"
2	2½"	2½"
2½	2½"	3½"
3	3½"	4½"
3½	3¾"	5½"
4	4¼"	5¾"
4½	4¾"	6½"
5	5¼"	7¼"
5½	5¾"	8"
6	6½"	8¾"
6½	6¾"	9½"
7	7¾"	10¼"
7½	8"	10 ⁵ / ₈ "
8	8½"	11 ⁵ / ₈ "
8½	9"	12 ³ / ₈ "
9	9½"	13 ³ / ₈ "
9½	10 ⁵ / ₈ "	13 ³ / ₈ "
10	10 ⁵ / ₈ "	14½"
10½	11 ⁵ / ₈ "	15¼"
11	11 ⁵ / ₈ "	16"
11½	12 ¹ / ₈ "	16¾"

Spacing In.	Jack Rafter Length
1	1"
2	2½"
3	3½"
4	4¼"
5	5¼"
6	6½"
7	7½"
8	8½"
9	9½"
10	10½"
11	11½"
12	1' 0 ⁵ / ₈ "
13	1' 1¾"
14	1' 2¾"
15	1' 3¾"
16	1' 4¾"
17	1' 5 ⁵ / ₈ "
18	1' 7"
19	1' 8"
20	1' 9 ⁵ / ₈ "
21	1' 10 ⁵ / ₈ "
22	1' 11¼"
23	2' 0¼"
24	2' 1¼"

Rafter Thickness	Miter Allowance for Hip and Valley Rafters	Rafter Depth	Bottom Allowance
1½"	1 ³ / ₁₆ "	3½"	1 ³ / ₁₆ "
1½"	7 ¹ / ₈ "	5½"	1 ³ / ₁₆ "
1¾"	1 ⁵ / ₁₆ "	7¼"	2 ¹ / ₁₆ "
1¾"	1"	9¼"	3 ¹ / ₁₆ "

5 INCH RISE 5-12 PITCH 22½ DEGREES

Run Ft.	Common Rafter Length	Hip or Val. Rafter Length
1	1' 1"	1' 5¼"
2	2' 2"	2' 11¾"
3	3' 3"	4' 5½"
4	4' 4"	5' 10¾"
5	5' 5"	7' 4½"
6	6' 6"	8' 10½"
7	7' 7"	10' 3¾"
8	8' 8"	11' 9½"
9	9' 9"	13' 3¼"
10	10' 10"	14' 8¾"
11	11' 11"	16' 2½"
12	13' 0"	17' 8¼"
13	14' 1"	19' 2"
14	15' 2"	20' 7¾"
15	16' 3"	22' 1¾"
16	17' 4"	23' 7½"
17	18' 5"	25' 0¾"
18	19' 6"	26' 6½"
19	20' 7"	28' 0½"
20	21' 8"	29' 5¾"
21	22' 9"	30' 11½"
22	23' 10"	32' 5¼"
23	24' 11"	33' 10½"
24	26' 0"	35' 4¾"
25	27' 1"	36' 10¼"

Run In.	Common Rafter Length	Hip or Val. Rafter Length
½	½"	¾"
1	1½"	1½"
1½	1½"	2¼"
2	2½"	3"
2½	2¾"	3½"
3	3¼"	4¾"
3½	3¾"	5½"
4	4¾"	5½"
4½	4¾"	6½"
5	5¾"	7¾"
5½	6"	8½"
6	6½"	8¾"
6½	7"	9½"
7	7¾"	10¾"
7½	8½"	11½"
8	8¾"	11½"
8½	9¼"	12½"
9	9¾"	13¼"
9½	10¼"	14"
10	10¾"	14¾"
10½	11¾"	15½"
11	11¾"	16¼"
11½	12½"	17"

Spacing In.	Jack Rafter Length
1	1½"
2	2½"
3	3¼"
4	4¾"
5	5¾"
6	6½"
7	7¾"
8	8¾"
9	9¾"
10	10½"
11	11½"
12	1' 1"
13	1' 2½"
14	1' 3½"
15	1' 4¼"
16	1' 5¾"
17	1' 6¾"
18	1' 7½"
19	1' 8½"
20	1' 9½"
21	1' 10¼"
22	1' 11½"
23	2' 0½"
24	2' 2"

Rafter Thickness	Miter Allowance for Hip and Valley Rafters	Rafter Depth	Bottom Allowance
1½"	1¾"	3½"	1½"
1¾"	1¾"	5½"	2½"
2"	1¾"	7¼"	3"
2½"	1"	9¼"	3½"

6 INCH RISE 6-12 PITCH 26½ DEGREES

Run Ft.	Common Rafter Length	Hip or Val. Rafter Length
1	1' 1⅜"	1' 6"
2	2' 2½"	3' 0"
3	3' 4¼"	4' 6"
4	4' 5½"	6' 0"
5	5' 7⅞"	7' 6"
6	6' 8½"	9' 0"
7	7' 9⅞"	10' 6"
8	8' 11⅜"	12' 0"
9	10' 0¼"	13' 6"
10	11' 2½"	15' 0"
11	12' 3⅝"	16' 6"
12	13' 5"	18' 0"
13	14' 6⅜"	19' 6"
14	15' 7⅞"	21' 0"
15	16' 9¼"	22' 6"
16	17' 10⅝"	24' 0"
17	19' 0⅞"	25' 6"
18	20' 1½"	27' 0"
19	21' 2⅞"	28' 6"
20	22' 4⅞"	30' 0"
21	23' 5¾"	31' 6"
22	24' 7⅞"	33' 0"
23	25' 8⅞"	34' 6"
24	26' 10"	36' 0"
25	27' 11⅜"	37' 6"

Run In.	Common Rafter Length	Hip or Val. Rafter Length
½	½"	¾"
1	1⅞"	1½"
1½	1⅞"	2¼"
2	2¼"	3"
2½	2¾"	3¾"
3	3⅞"	4½"
3½	3⅞"	5¼"
4	4½"	6"
4½	5"	6¾"
5	5⅞"	7½"
5½	6⅞"	8¼"
6	6¾"	9"
6½	7¼"	9¾"
7	7⅞"	10½"
7½	8⅞"	11¼"
8	9"	12"
8½	9½"	12¾"
9	10⅞"	13½"
9½	10⅞"	14¼"
10	11¼"	15"
10½	11¾"	15¾"
11	12⅞"	16½"
11½	12⅞"	17¼"

Spacing In.	Jack Rafter Length
1	1⅞"
2	2¼"
3	3⅜"
4	4½"
5	5⅞"
6	6¾"
7	7⅞"
8	9"
9	10⅞"
10	11⅞"
11	1' 0¼"
12	1' 1⅜"
13	1' 2½"
14	1' 3⅝"
15	1' 4¾"
16	1' 5⅞"
17	1' 7"
18	1' 8⅞"
19	1' 9¼"
20	1' 10⅞"
21	1' 11½"
22	2' 0⅞"
23	2' 1¾"
24	2' 2⅞"

Rafter Thickness	Miter Allowance for Hip and Valley Rafters	Rafter Depth	Bottom Allowance
1½"	⅜"	3½"	1¼"
1⅞"	⅝"	5½"	2¾"
1¾"	1"	7¼"	3⅞"
1⅞"	1⅞"	9¼"	4⅞"

7 INCH RISE 7-12 PITCH 30¼ DEGREES

Run Ft.	Common Rafter Length	Hip or Val. Rafter Length
1	1' 1½"	1' 6¾"
2	2' 3¼"	3' 0¾"
3	3' 5½"	4' 7½"
4	4' 7½"	6' 1¾"
5	5' 9½"	7' 7¾"
6	6' 11¾"	9' 2½"
7	8' 1¼"	10' 8½"
8	9' 3½"	12' 2½"
9	10' 5"	13' 9¼"
10	11' 6½"	15' 3¾"
11	12' 8½"	16' 9½"
12	13' 10¾"	18' 4¼"
13	15' 0½"	19' 10½"
14	16' 2½"	21' 5"
15	17' 4½"	22' 11¾"
16	18' 6¼"	24' 5¾"
17	19' 8½"	26' 0½"
18	20' 10"	27' 6¾"
19	22' 0"	29' 0¾"
20	23' 1½"	30' 7½"
21	24' 3¼"	32' 1½"
22	25' 5½"	33' 7½"
23	26' 7½"	35' 2¼"
24	27' 9¾"	36' 8½"
25	28' 11¼"	38' 2½"

Run In.	Common Rafter Length	Hip or Val. Rafter Length
½	5⁄8"	¾"
1	1½"	1½"
1½	1¾"	2¼"
2	2¾"	3"
2½	2¾"	3¾"
3	3½"	4½"
3½	4"	5½"
4	4½"	6½"
4½	5¼"	6¾"
5	5¾"	7½"
5½	6¾"	8½"
6	6¾"	9½"
6½	7½"	9¾"
7	8"	10 5⁄8"
7½	8½"	11¾"
8	9¼"	12½"
8½	9¾"	13"
9	10¾"	13¾"
9½	10¾"	14½"
10	11½"	15¼"
10½	12½"	16"
11	12½"	16¾"
11½	13¼"	17½"

Spacing In.	Jack Rafter Length
1	1 ⅛"
2	2 ⅜"
3	3 ½"
4	4 ⅝"
5	5 ¾"
6	7"
7	8 ⅛"
8	9 ¼"
9	10 ⅝"
10	11 ⅞"
11	1' 0 ¼"
12	1' 1 ⅛"
13	1' 3"
14	1' 4 ¼"
15	1' 5 ⅝"
16	1' 6 ½"
17	1' 7 ⅞"
18	1' 8 ⅞"
19	1' 10"
20	1' 11 ⅛"
21	2' 0 ¼"
22	2' 1 ½"
23	2' 2 ⅝"
24	2' 3 ¾"

Rafter Thickness	Miter Allowance for Hip and Valley Rafters	Rafter Depth	Bottom Allowance
1½"	⅜"	3½"	2 ⅙"
1⅝"	15⁄16"	5½"	3 ⅙"
1¾"	1"	7¼"	4¼"
1⅞"	1 ⅙"	9¼"	5¾"

8 INCH RISE 8-12 PITCH 33³/₄ DEGREES

Run Ft.	Common Rafter Length	Hip or Val. Rafter Length
1	1' 2 ³ / ₈ "	1' 6 ³ / ₄ "
2	2' 4 ⁷ / ₈ "	3' 1 ¹ / ₂ "
3	3' 7 ¹ / ₄ "	4' 8 ¹ / ₄ "
4	4' 9 ³ / ₄ "	6' 3"
5	6' 0 ¹ / ₈ "	7' 9 ³ / ₄ "
6	7' 2 ¹ / ₂ "	9' 4 ⁵ / ₈ "
7	8' 5"	10' 11 ³ / ₈ "
8	9' 7 ³ / ₈ "	12' 6 ¹ / ₈ "
9	10' 9 ³ / ₄ "	14' 0 ⁷ / ₈ "
10	12' 0 ¹ / ₄ "	15' 7 ⁵ / ₈ "
11	13' 2 ⁵ / ₈ "	17' 2 ³ / ₈ "
12	14' 5 ¹ / ₈ "	18' 9 ¹ / ₈ "
13	15' 7 ¹ / ₂ "	20' 3 ³ / ₈ "
14	16' 9 ⁵ / ₈ "	21' 10 ⁵ / ₈ "
15	18' 0 ³ / ₈ "	23' 5 ³ / ₈ "
16	19' 2 ³ / ₄ "	25' 0 ¹ / ₈ "
17	20' 5 ¹ / ₈ "	26' 7"
18	21' 7 ⁵ / ₈ "	28' 1 ³ / ₄ "
19	22' 10"	29' 8 ¹ / ₂ "
20	24' 0 ¹ / ₂ "	31' 3 ¹ / ₄ "
21	25' 2 ¹ / ₈ "	32' 10"
22	26' 5 ¹ / ₄ "	34' 4 ³ / ₄ "
23	27' 7 ¹ / ₄ "	35' 11 ¹ / ₂ "
24	28' 10 ¹ / ₈ "	37' 6 ¹ / ₄ "
25	30' 0 ¹ / ₂ "	39' 1"

Run In.	Common Rafter Length	Hip or Val. Rafter Length
1/2	5/8"	3/4"
1	1 1/4"	1 5/8"
1 1/2	1 3/4"	2 3/8"
2	2 3/8"	3 1/8"
2 1/2	3"	3 3/8"
3	3 3/8"	4 3/4"
3 1/2	4 1/4"	5 1/2"
4	4 3/4"	6 1/4"
4 1/2	5 3/8"	7"
5	6"	7 5/8"
1/2	6 5/8"	8 5/8"
6	7 1/4"	9 3/8"
6 1/2	7 5/8"	10 1/8"
7	8 1/2"	11"
7 1/2	9"	11 3/4"
8	9 5/8"	12 1/2"
8 1/2	10 1/4"	13 1/4"
9	10 5/8"	14 1/8"
9 1/2	11 1/2"	14 5/8"
10	12"	15 5/8"
10 1/2	12 5/8"	16 3/8"
11	13 1/4"	17 1/4"
11 1/2	13 3/8"	18"

Spacing In.	Jack Rafter Length
1	1 1/4"
2	2 3/8"
3	3 5/8"
4	4 3/4"
5	6"
6	7 1/4"
7	8 3/8"
8	9 5/8"
9	10 5/8"
10	1' 0"
11	1' 1 1/4"
12	1' 2 3/8"
13	1' 3 5/8"
14	1' 4 7/8"
15	1' 6"
16	1' 7 1/4"
17	1' 8 3/8"
18	1' 9 5/8"
19	1' 10 7/8"
20	2' 0"
21	2' 1 1/4"
22	2' 2 1/2"
23	2' 3 5/8"
24	2' 4 7/8"

Rafter Thickness	Miter Allowance for Hip and Valley Rafters	Rafter Depth	Bottom Allowance
1 1/2"	7/8"	1/2"	2 5/16"
1 5/8"	1"	5/2"	3 1/16"
1 3/4"	1 1/16"	7/4"	4 13/16"
1 7/8"	1 1/8"	9/4"	6 3/16"

9 INCH RISE 9-12 PITCH 37 DEGREES

Run Ft.	Common Rafter Length	Hip or Val. Rafter Length
1	1' 3"	1' 7¼"
2	2' 6"	3' 2½"
3	3' 9"	4' 9½"
4	5' 0"	6' 4½"
5	6' 3"	8' 0"
6	7' 6"	9' 7¼"
7	8' 9"	11' 2½"
8	10' 0"	12' 9½"
9	11' 3"	14' 4½"
10	12' 6"	16' 0½"
11	13' 9"	17' 7¼"
12	15' 0"	19' 2½"
13	16' 3"	20' 9¾"
14	17' 6"	22' 4½"
15	18' 9"	24' 0½"
16	20' 0"	25' 7½"
17	21' 3"	27' 2½"
18	22' 6"	28' 9¾"
19	23' 9"	30' 5"
20	25' 0"	32' 0½"
21	26' 3"	33' 7½"
22	27' 6"	35' 2½"
23	28' 9"	36' 9¾"
24	30' 0"	38' 5"
25	31' 3"	40' 0¼"

Run In.	Common Rafter Length	Hip or Val. Rafter Length
½	⅝"	¾"
1	1¼"	1⅝"
1½	1⅞"	2⅝"
2	2½"	3¼"
2½	3⅞"	4"
3	3¾"	4¾"
3½	4⅝"	5⅝"
4	5"	6⅝"
4½	5⅝"	7¼"
5	6¼"	8"
5½	6⅞"	8¾"
6	7½"	9⅝"
6½	8⅞"	10⅝"
7	8¾"	11¼"
7½	9⅝"	12"
8	10"	12⅝"
8½	10⅝"	13⅝"
9	11¼"	14⅝"
9½	11⅞"	15¼"
10	12½"	16"
10½	13⅞"	16⅞"
11	13¾"	17⅝"
11½	14⅝"	18⅝"

Spacing In.	Jack Rafter Length
1	1¼"
2	2½"
3	3¾"
4	5"
5	6¼"
6	7½"
7	8¾"
8	10"
9	11¼"
10	1' 0½"
11	1' 1¾"
12	1' 3"
13	1' 4¼"
14	1' 5½"
15	1' 6¾"
16	1' 8"
17	1' 9¼"
18	1' 10½"
19	1' 11¾"
20	2' 1"
21	2' 2¼"
22	2' 3½"
23	2' 4¾"
24	2' 6"

Rafter Thickness	Miter Allowance for Hip and Valley Rafters	Rafter Depth	Bottom Allowance
1½"	⅝"	3½"	2⅝"
1⅝"	1"	5½"	4⅝"
1¾"	1⅞"	7¼"	5⅞"
1⅞"	1⅝"	9¼"	6⅞"

10 INCH RISE 10-12 PITCH 40 DEGREES

Run Ft.	Common Rafter Length	Hip or Val. Rafter Length
1	1' 3 ⁵ / ₈ "	1' 7 ³ / ₄ "
2	2' 7 ¹ / ₄ "	3' 3 ³ / ₈ "
3	3' 10 ⁵ / ₈ "	4' 11 ¹ / ₈ "
4	5' 2 ¹ / ₂ "	6' 6 ³ / ₄ "
5	6' 6 ¹ / ₈ "	8' 2 ¹ / ₂ "
6	7' 9 ³ / ₄ "	9' 10 ¹ / ₄ "
7	9' 1 ³ / ₈ "	11' 5 ³ / ₈ "
8	10' 5"	13' 1 ⁵ / ₈ "
9	11' 8 ⁵ / ₈ "	14' 9 ¹ / ₄ "
10	13' 0 ¹ / ₄ "	16' 5"
11	14' 3 ³ / ₈ "	18' 0 ⁵ / ₈ "
12	15' 7 ¹ / ₂ "	19' 8 ³ / ₈ "
13	16' 11"	21' 4 ¹ / ₈ "
14	18' 2 ⁵ / ₈ "	22' 11 ³ / ₄ "
15	19' 6 ¹ / ₄ "	24' 7 ¹ / ₂ "
16	20' 10"	26' 3 ¹ / ₈ "
17	22' 1 ¹ / ₂ "	27' 10 ⁵ / ₈ "
18	23' 5 ¹ / ₈ "	28' 6 ⁵ / ₈ "
19	24' 8 ³ / ₄ "	31' 2 ¹ / ₄ "
20	26' 0 ³ / ₈ "	32' 10"
21	27' 4"	34' 5 ⁵ / ₈ "
22	28' 7 ⁵ / ₈ "	36' 1 ³ / ₈ "
23	29' 11 ¹ / ₄ "	37' 9"
24	31' 2 ⁵ / ₈ "	39' 4 ³ / ₄ "
25	32' 6 ¹ / ₂ "	41' 0 ¹ / ₂ "

Run In.	Common Rafter Length	Hip or Val. Rafter Length
1/2	5 ⁵ / ₈ "	7 ³ / ₈ "
1	1 ¹ / ₄ "	1 ⁵ / ₈ "
1 1/2	2"	2 ¹ / ₂ "
2	2 ⁵ / ₈ "	3 ¹ / ₄ "
2 1/2	3 ¹ / ₄ "	4 ¹ / ₈ "
3	3 ³ / ₈ "	4 ³ / ₈ "
3 1/2	4 ¹ / ₂ "	5 ³ / ₄ "
4	5 ¹ / ₄ "	6 ⁵ / ₈ "
4 1/2	5 ⁵ / ₈ "	7 ³ / ₈ "
5	6 ¹ / ₂ "	8 ¹ / ₄ "
5 1/2	7 ¹ / ₈ "	9"
6	7 ³ / ₄ "	9 ³ / ₈ "
6 1/2	8 ³ / ₈ "	10 ³ / ₄ "
7	9"	11 ¹ / ₂ "
7 1/2	9 ³ / ₄ "	12 ³ / ₈ "
8	10 ⁵ / ₈ "	13 ³ / ₈ "
8 1/2	11"	14"
9	11 ⁵ / ₈ "	14 ³ / ₄ "
9 1/2	12 ¹ / ₄ "	15 ⁵ / ₈ "
10	13"	16 ¹ / ₂ "
10 1/2	13 ³ / ₈ "	17 ¹ / ₄ "
11	14 ¹ / ₄ "	18 ¹ / ₈ "
11 1/2	14 ³ / ₈ "	18 ³ / ₈ "

Spacing In.	Jack Rafter Length
1	1 ¹ / ₄ "
2	2 ⁵ / ₈ "
3	3 ³ / ₈ "
4	5 ¹ / ₄ "
5	6 ¹ / ₂ "
6	7 ³ / ₄ "
7	9 ¹ / ₈ "
8	10 ³ / ₈ "
9	11 ³ / ₄ "
10	1' 1"
11	1' 2 ³ / ₈ "
12	1' 3 ³ / ₈ "
13	1' 4 ³ / ₈ "
14	1' 6 ¹ / ₄ "
15	1' 7 ¹ / ₂ "
16	1' 8 ³ / ₈ "
17	1' 10 ¹ / ₈ "
18	1' 11 ³ / ₈ "
19	2' 0 ³ / ₄ "
20	2' 2"
21	2' 3 ³ / ₈ "
22	2' 4 ⁵ / ₈ "
23	2' 6"
24	2' 7 ¹ / ₄ "

Rafter Thickness	Miter Allowance for Hip and Valley Rafters	Rafter Depth	Bottom Allowance
1 ¹ / ₂ "	1"	3 ¹ / ₂ "	2 ¹ / ₁₆ "
1 ⁵ / ₈ "	1 ¹ / ₁₆ "	5 ¹ / ₂ "	4 ⁹ / ₁₆ "
1 ³ / ₄ "	1 ¹ / ₈ "	7 ¹ / ₄ "	6 ¹ / ₁₆ "
1 ¹ / ₈ "	1 ¹ / ₄ "	9 ¹ / ₄ "	7 ¹ / ₁₆ "

11 INCH RISE 11-12 PITCH 42½ DEGREES

Run Ft.	Common Rafter Length	Hip or Val. Rafter Length
1	1' 4¼"	1' 8¼"
2	2' 8½"	3' 4½"
3	4' 0⅞"	5' 0⅞"
4	5' 5⅞"	6' 8⅞"
5	6' 9⅞"	8' 5⅞"
6	8' 1⅞"	10' 1⅞"
7	9' 6"	11' 9⅝"
8	10' 10¼"	13' 5¾"
9	12' 2½"	15' 2"
10	13' 6¾"	16' 10¼"
11	14' 11"	18' 6½"
12	16' 3⅞"	20' 2¾"
13	17' 7⅞"	21' 10⅞"
14	18' 11⅞"	23' 7⅞"
15	20' 4⅞"	25' 3⅞"
16	21' 8½"	26' 11⅞"
17	23' 0¾"	28' 7¼"
18	24' 5"	30' 4"
19	25' 9¼"	32' 0¼"
20	27' 1½"	33' 8½"
21	28' 5⅞"	35' 4¾"
22	29' 10⅞"	37' 0⅞"
23	31' 2⅞"	38' 9⅞"
24	32' 6⅞"	40' 5⅞"
25	33' 11"	42' 1⅞"

Run In.	Common Rafter Length	Hip or Val. Rafter Length
½	⅝"	⅞"
1	1⅜"	1⅝"
1½	2"	2½"
2	2¾"	3⅜"
2½	3⅞"	4¼"
3	4⅞"	5"
3½	4¾"	5⅞"
4	5⅞"	6¾"
4½	6⅞"	7⅞"
5	6¾"	8⅞"
5½	7½"	9¼"
6	8⅞"	10⅞"
6½	8¾"	11"
7	9½"	11¾"
7½	10⅞"	12⅝"
8	10⅞"	13½"
8½	11½"	14⅜"
9	12¼"	15⅞"
9½	12⅞"	16"
10	13½"	16⅞"
10½	14¼"	17¾"
11	14⅞"	18½"
11½	15⅞"	19⅞"

Spacing In.	Jack Rafter Length
1	1⅜"
2	2¾"
3	4⅞"
4	5⅞"
5	6¾"
6	8⅞"
7	9½"
8	10⅞"
9	1' 0¼"
10	1' 1⅝"
11	1' 2⅞"
12	1' 4¼"
13	1' 5⅞"
14	1' 7"
15	1' 8⅞"
16	1' 9¼"
17	1' 11"
18	2' 0⅞"
19	2' 1¾"
20	2' 3⅞"
21	2' 4½"
22	2' 5⅞"
23	2' 7¼"
24	2' 8½"

Rafter Thickness	Miter Allowance for Hip and Valley Rafters	Rafter Depth	Bottom Allowance
1½"	1"	3½"	3⅞"
1⅞"	1⅞"	5½"	5⅞"
1¾"	1⅞"	7¼"	6⅞"
1⅞"	1¼"	9¼"	8½"

12 INCH RISE 12-12 PITCH 45 DEGREES

Run Ft.	Common Rafter Length	Hip or Val. Rafter Length
1	1' 5"	1' 8 ³ / ₄ "
2	2' 10"	3' 5 ⁵ / ₈ "
3	4' 2 ¹ / ₂ "	5' 2 ³ / ₈ "
4	5' 7 ¹ / ₂ "	6' 11 ¹ / ₈ "
5	7' 0 ¹ / ₂ "	8' 7 ¹ / ₂ "
6	8' 5 ⁵ / ₈ "	10' 4 ³ / ₄ "
7	9' 10 ³ / ₄ "	12' 1 ¹ / ₂ "
8	11' 3 ³ / ₄ "	13' 10 ¹ / ₄ "
9	12' 8 ³ / ₄ "	15' 7"
10	14' 1 ³ / ₄ "	17' 3 ³ / ₄ "
11	15' 6 ⁵ / ₈ "	19' 0 ⁵ / ₈ "
12	16' 11 ⁵ / ₈ "	20' 9 ³ / ₈ "
13	18' 4 ⁵ / ₈ "	22' 6 ¹ / ₄ "
14	19' 9 ⁵ / ₈ "	24' 3"
15	21' 2 ¹ / ₂ "	25' 11 ¹ / ₄ "
16	22' 7 ¹ / ₂ "	27' 8 ¹ / ₂ "
17	24' 0 ¹ / ₂ "	29' 5 ³ / ₈ "
18	25' 5 ¹ / ₂ "	31' 2 ¹ / ₈ "
19	26' 10 ⁵ / ₈ "	32' 10 ⁵ / ₈ "
20	28' 3 ⁵ / ₈ "	34' 7 ⁵ / ₈ "
21	29' 8 ⁵ / ₈ "	36' 4 ¹ / ₂ "
22	31' 1 ⁵ / ₈ "	38' 1 ¹ / ₄ "
23	32' 6 ¹ / ₄ "	39' 10"
24	33' 11 ¹ / ₄ "	41' 6 ³ / ₈ "
25	35' 4 ¹ / ₄ "	43' 3 ⁵ / ₈ "

Run In.	Common Rafter Length	Hip or Val. Rafter Length
1/2	3/4"	7/8"
1	1 1/8"	1 1/4"
1 1/2	2 1/8"	2 5/8"
2	2 3/8"	3 1/2"
2 1/2	3 1/2"	4 3/8"
3	4 1/4"	5 1/4"
3 1/2	5"	6"
4	5 5/8"	6 3/8"
4 1/2	6 3/8"	7 3/4"
5	7 1/8"	8 1/8"
5 1/2	7 3/4"	9 1/2"
6	8 1/2"	10 5/8"
6 1/2	9 1/4"	11 1/4"
7	9 5/8"	12 1/8"
7 1/2	10 5/8"	13"
8	11 5/8"	13 3/8"
8 1/2	12"	14 3/4"
9	12 3/4"	15 5/8"
9 1/2	13 1/2"	16 5/8"
10	14 1/8"	17 1/4"
10 1/2	14 7/8"	18 1/8"
11	15 5/8"	19"
11 1/2	16 1/4"	19 5/8"

Spacing In.	Jack Rafter Length
1	1 3/8"
2	2 5/8"
3	4 1/4"
4	5 5/8"
5	7 1/8"
6	8 1/2"
7	9 5/8"
8	11 3/8"
9	1' 0 3/4"
10	1' 2 1/8"
11	1' 3 1/2"
12	1' 5"
13	1' 6 3/8"
14	1' 7 3/4"
15	1' 9 1/4"
16	1' 10 5/8"
17	2' 0"
18	2' 1 1/2"
19	2' 2 5/8"
20	2' 4 1/4"
21	2' 5 3/4"
22	2' 7 1/8"
23	2' 8 1/2"
24	2' 9 5/8"

Rafter Thickness	Miter Allowance for Hip and Valley Rafters	Rafter Depth	Bottom Allowance
1 1/2"	1 1/8"	3 1/2"	3 1/2"
1 5/8"	1 1/8"	5 1/2"	5 1/2"
1 3/4"	1 1/4"	7 1/4"	7 1/4"
1 7/8"	1 5/8"	9 1/4"	9 1/4"

13 INCH RISE 13-12 PITCH 47¼ DEGREES

Run Ft.	Common Rafter Length	Hip or Val. Rafter Length
1	1' 5¼"	1' 9½"
2	2' 11⅝"	3' 6¾"
3	4' 5⅞"	5' 4⅞"
4	5' 10¾"	7' 1½"
5	7' 4½"	8' 10⅞"
6	8' 10⅞"	10' 8¼"
7	10' 3⅞"	12' 5⅝"
8	11' 9½"	14' 3"
9	13' 3¼"	16' 0⅞"
10	14' 8⅞"	17' 9¼"
11	16' 2⅞"	19' 7⅞"
12	17' 8⅞"	21' 4½"
13	19' 2"	23' 1⅞"
14	20' 7¼"	24' 11¼"
15	22' 1⅞"	26' 8⅝"
16	23' 7⅞"	28' 6"
17	25' 0¼"	30' 3⅞"
18	26' 6½"	32' 0¼"
19	28' 0⅞"	33' 10⅞"
20	29' 5⅞"	35' 7½"
21	30' 11½"	37' 4⅞"
22	32' 5¼"	39' 2¼"
23	33' 10⅞"	40' 11⅞"
24	35' 4⅞"	42' 9"
25	36' 10¼"	44' 6⅞"

Run In.	Common Rafter Length	Hip or Val. Rafter Length
½	¾"	⅞"
1	1½"	1¾"
1½	2¼"	2⅞"
2	3"	3½"
2½	3⅝"	4½"
3	4⅞"	5⅞"
3½	5⅞"	6¼"
4	5⅞"	7⅞"
4½	6⅞"	8"
5	7⅞"	8⅞"
5½	8⅞"	9¼"
6	8⅞"	10⅞"
6½	9⅞"	11½"
7	10⅞"	12⅞"
7½	10⅞"	13¼"
8	11⅞"	14⅞"
8½	12¼"	15⅞"
9	13"	16"
9½	13¼"	16⅞"
10	14½"	17¼"
10½	15¼"	18⅞"
11	16"	19½"
11½	16¼"	20⅞"

Spacing In.	Jack Rafter Length
1	1½"
2	3"
3	4⅞"
4	5⅞"
5	7⅞"
6	8⅞"
7	10⅞"
8	11¼"
9	1' 1¼"
10	1' 2¼"
11	1' 4¼"
12	1' 5¾"
13	1' 7⅞"
14	1' 8⅞"
15	1' 10⅞"
16	1' 11⅞"
17	2' 1⅞"
18	2' 2½"
19	2' 4"
20	2' 5½"
21	2' 7"
22	2' 8⅞"
23	2' 9⅞"
24	2' 11⅞"

Rafter Thickness	Miter Allowance for Hip and Valley Rafters	Rafter Depth	Bottom Allowance
1½"	1⅞"	3½"	3⅜"
1⅞"	1⅞"	5½"	5⅜"
1¾"	1⅞"	7¼"	7⅞"
1⅞"	1⅞"	9¼"	10"

14 INCH RISE 14-12 PITCH 49½ DEGREES

Run Ft.	Common Rafter Length	Hip or Val. Rafter Length
1	1' 6½"	1' 10"
2	3' 0½"	3' 8"
3	4' 7¾"	5' 6"
4	6' 1¾"	7' 4"
5	7' 8¼"	9' 2"
6	9' 2½"	11' 0"
7	10' 9½"	12' 10"
8	12' 3½"	14' 8"
9	13' 10"	16' 6"
10	15' 4¾"	18' 4"
11	16' 10⅝"	20' 2"
12	18' 5¼"	22' 0"
13	19' 11¼"	23' 10"
14	21' 6½"	25' 8"
15	23' 0⅝"	27' 6"
16	24' 7"	29' 4"
17	26' 1½"	31' 2"
18	27' 7⅝"	33' 0"
19	29' 2⅜"	34' 10"
20	30' 8¾"	36' 8"
21	32' 3½"	38' 6"
22	33' 9⅝"	40' 4"
23	35' 4½"	42' 2"
24	36' 10½"	44' 0"
25	38' 5"	45' 10"

Run In.	Common Rafter Length	Hip or Val. Rafter Length
½	¾"	⅞"
1	1½"	1⅞"
1½	2¼"	2¾"
2	3⅛"	3⅝"
2½	3⅞"	4⅝"
3	4⅝"	5½"
3½	5⅜"	6⅜"
4	6⅞"	7⅜"
4½	6⅞"	8¼"
5	7⅝"	9⅞"
5½	8½"	10⅞"
6	9¼"	11"
6½	10"	11⅞"
7	10¾"	12⅞"
7½	11½"	13¾"
8	12⅝"	14⅝"
8½	13⅞"	15⅝"
9	13⅞"	16½"
9½	14⅝"	17⅞"
10	15⅝"	18⅝"
10½	16⅞"	19¼"
11	16⅞"	20⅞"
11½	17¼"	21⅞"

Spacing In.	Jack Rafter Length
1	1½"
2	3⅞"
3	4⅝"
4	6⅞"
5	7⅝"
6	9¼"
7	10¾"
8	1' 0¼"
9	1' 1⅞"
10	1' 3⅜"
11	1' 4⅞"
12	1' 6½"
13	1' 8"
14	1' 9½"
15	1' 11"
16	2' 0⅝"
17	2' 2⅞"
18	2' 3⅝"
19	2' 5¼"
20	2' 6¾"
21	2' 8¼"
22	2' 9⅞"
23	2' 11⅜"
24	3' 0⅞"

Rafter Thickness	Miter Allowance for Hip and Valley Rafters	Rafter Depth	Bottom Allowance
1½"	1⅞"	3½"	4⅞"
1⅝"	1¼"	5½"	6⅞"
1¾"	1⅝"	7¼"	8⅞"
1⅞"	1⅞"	9¼"	10⅞"

15 INCH RISE 15-12 PITCH 51½ DEGREES

Run Ft.	Common Rafter Length	Hip or Val. Rafter Length
1	1' 7¼"	1' 10⅝"
2	3' 2⅜"	3' 9¼"
3	4' 9⅝"	5' 8"
4	6' 4⅞"	7' 6⅝"
5	8' 0"	9' 5¼"
6	9' 7¼"	11' 3⅞"
7	11' 2½"	13' 2½"
8	12' 9⅝"	15' 1¼"
9	14' 4⅞"	16' 11⅞"
10	16' 0⅞"	18' 10½"
11	17' 7⅞"	20' 9⅞"
12	19' 2½"	22' 7¾"
13	20' 9¾"	24' 6½"
14	22' 4⅞"	26' 5⅞"
15	24' 0⅞"	28' 3¾"
16	25' 7⅞"	30' 2⅜"
17	27' 2½"	32' 1"
18	28' 9¾"	33' 11¼"
19	30' 5"	35' 10⅝"
20	32' 0¼"	37' 9"
21	33' 7⅞"	39' 7⅞"
22	35' 2⅝"	41' 6¼"
23	36' 9⅞"	43' 4⅞"
24	38' 5"	45' 3⅞"
25	40' 0¼"	47' 2¼"

Run In.	Common Rafter Length	Hip or Val. Rafter Length
½	¾"	1"
1	1⅝"	1⅞"
1½	2⅝"	2⅞"
2	3¼"	3¾"
2½	4"	4¾"
3	4¾"	5⅝"
3½	5⅝"	6⅝"
4	6 3/8"	7 1/2"
4½	7¼"	8½"
5	8"	9½"
5½	8¾"	10⅝"
6	9⅝"	11⅝"
6½	10⅝"	12⅝"
7	11¼"	13¼"
7½	12"	14¼"
8	12⅞"	15⅞"
8½	13⅝"	16⅞"
9	14⅝"	17"
9½	15¼"	18"
10	16"	18⅝"
10½	16⅞"	19⅞"
11	17⅝"	20⅞"
11½	18⅝"	21¾"

Spacing In.	Jack Rafter Length
1	1⅝"
2	3¼"
3	4¾"
4	6⅝"
5	8"
6	9⅝"
7	11¼"
8	1' 0¾"
9	1' 2⅝"
10	1' 4"
11	1' 5⅝"
12	1' 7¼"
13	1' 8⅞"
14	1' 10⅝"
15	2' 0"
16	2' 1⅝"
17	2' 3¼"
18	2' 4⅞"
19	2' 6⅝"
20	2' 8"
21	2' 9⅝"
22	2' 11¼"
23	3' 0⅞"
24	3' 2⅝"

Rafter Thickness	Miter Allowance for Hip and Valley Rafters	Rafter Depth	Bottom Allowance
1½"	1⅜"	3½"	4⅞"
1⅝"	1⅝"	5½"	6⅞"
1¾"	1⅞"	7¼"	9⅞"
1⅞"	1½"	9¼"	11⅞"

16 INCH RISE 16-12 PITCH 53¼ DEGREES

Run Ft.	Common Rafter Length	Hip or Val. Rafter Length
1	1' 8"	1' 11 ³ / ₈ "
2	3' 4"	3' 10 ⁵ / ₈ "
3	5' 0"	5' 10"
4	6' 8"	7' 9 ¹ / ₄ "
5	8' 4"	9' 8 ⁵ / ₈ "
6	10' 0"	11' 8"
7	11' 8"	13' 7 ¹ / ₄ "
8	13' 4"	15' 6 ⁵ / ₈ "
9	15' 0"	17' 5 ¹ / ₂ "
10	16' 8"	19' 5 ¹ / ₄ "
11	18' 4"	21' 4 ⁵ / ₈ "
12	20' 0"	23' 3 ¹ / ₂ "
13	21' 8"	25' 3 ¹ / ₄ "
14	23' 4"	27' 2 ¹ / ₂ "
15	25' 0"	29' 1 ¹ / ₂ "
16	26' 8"	31' 1 ¹ / ₈ "
17	28' 4"	33' 0 ¹ / ₂ "
18	30' 0"	34' 11 ¹ / ₈ "
19	31' 8"	36' 11 ¹ / ₈ "
20	33' 4"	38' 10 ¹ / ₂ "
21	35' 0"	40' 9 ³ / ₄ "
22	36' 8"	42' 9 ¹ / ₈ "
23	38' 4"	44' 8 ¹ / ₂ "
24	40' 0"	46' 7 ³ / ₄ "
25	41' 8"	48' 7 ¹ / ₈ "

Run In.	Common Rafter Length	Hip or Val. Rafter Length
½	7 ¹ / ₈ "	1"
1	1 ⁵ / ₈ "	2"
1½	2½"	2 ¹ / ₂ "
2	3 ³ / ₈ "	3 ³ / ₈ "
2½	4 ¹ / ₈ "	4 ¹ / ₈ "
3	5"	5 ¹ / ₈ "
3½	5 ⁵ / ₈ "	6 ¹ / ₄ "
4	6 ³ / ₈ "	7 ¹ / ₄ "
4½	7½"	8 ³ / ₄ "
5	8 ³ / ₈ "	9 ³ / ₄ "
5½	9 ¹ / ₈ "	10 ³ / ₄ "
6	10"	11 ¹ / ₈ "
6½	10 ⁵ / ₈ "	12 ⁵ / ₈ "
7	11 ³ / ₈ "	13 ³ / ₈ "
7½	12½"	14½"
8	13 ³ / ₈ "	15½"
8½	14 ¹ / ₈ "	16½"
9	15"	17½"
9½	15 ⁵ / ₈ "	18 ⁵ / ₈ "
10	16 ³ / ₈ "	19 ³ / ₈ "
10½	17½"	20 ³ / ₈ "
11	18 ³ / ₈ "	21 ³ / ₈ "
11½	19 ¹ / ₈ "	22 ³ / ₈ "

Spacing In.	Jack Rafter Length
1	1 ⁵ / ₈ "
2	3 ³ / ₈ "
3	5"
4	6 ⁵ / ₈ "
5	8 ³ / ₈ "
6	10"
7	11 ¹ / ₈ "
8	1' 1 ³ / ₈ "
9	1' 3"
10	1' 4 ⁵ / ₈ "
11	1' 6 ³ / ₈ "
12	1' 8"
13	1' 9 ⁵ / ₈ "
14	1' 11 ³ / ₈ "
15	2' 1"
16	2' 2 ⁵ / ₈ "
17	2' 4 ³ / ₈ "
18	2' 6"
19	2' 7 ¹ / ₈ "
20	2' 9 ³ / ₈ "
21	2' 11"
22	3' 0 ⁵ / ₈ "
23	3' 2 ³ / ₈ "
24	3' 4"

Rafter Thickness	Miter Allowance for Hip and Valley Rafters	Rafter Depth	Bottom Allowance
1½"	¼"	3½"	4 ¹ / ₁₆ "
1 ⁵ / ₈ "	1 ³ / ₈ "	5½"	7 ¹ / ₁₆ "
1¾"	1 ¹ / ₁₆ "	7¼"	9 ¹ / ₁₆ "
1 ⁷ / ₈ "	1 ¹ / ₁₆ "	9¼"	12 ⁵ / ₁₆ "

17 INCH RISE 17-12 PITCH 54³/₄ DEGREES

Run Ft.	Common Rafter Length	Hip or Val. Rafter Length
1	1' 8 ³ / ₄ "	2' 0"
2	3' 5 ⁵ / ₈ "	4' 0"
3	5' 2 ³ / ₈ "	6' 0 ¹ / ₈ "
4	6' 11 ¹ / ₄ "	8' 0 ¹ / ₈ "
5	8' 8"	10' 0 ¹ / ₈ "
6	10' 4 ⁷ / ₈ "	12' 0 ¹ / ₈ "
7	12' 1 ⁵ / ₈ "	14' 0 ¹ / ₈ "
8	13' 10 ¹ / ₂ "	16' 0 ¹ / ₈ "
9	15' 7 ¹ / ₄ "	18' 0 ¹ / ₄ "
10	17' 4 ¹ / ₈ "	20' 0 ¹ / ₄ "
11	19' 0 ⁵ / ₈ "	22' 0 ¹ / ₄ "
12	20' 9 ³ / ₄ "	24' 0 ¹ / ₄ "
13	22' 6 ¹ / ₂ "	26' 0 ¹ / ₄ "
14	24' 3 ³ / ₈ "	28' 0 ¹ / ₄ "
15	26' 0 ¹ / ₈ "	30' 0 ³ / ₈ "
16	27' 9"	32' 0 ³ / ₈ "
17	29' 5 ³ / ₄ "	34' 0 ³ / ₈ "
18	31' 2 ¹ / ₂ "	36' 0 ³ / ₈ "
19	32' 11 ⁵ / ₈ "	38' 0 ³ / ₈ "
20	34' 8 ¹ / ₈ "	40' 0 ³ / ₈ "
21	36' 5"	42' 0 ³ / ₈ "
22	38' 1 ³ / ₄ "	44' 0 ¹ / ₂ "
23	39' 10 ⁵ / ₈ "	46' 0 ¹ / ₂ "
24	41' 7 ³ / ₈ "	48' 0 ¹ / ₂ "
25	43' 4 ¹ / ₄ "	50' 0 ¹ / ₂ "

Run In.	Common Rafter Length	Hip or Val. Rafter Length
1/2	7/8"	1"
1	1 1/4"	2"
1 1/2	2 5/8"	3"
2	3 1/2"	4"
2 1/2	4 3/8"	5"
3	5 1/4"	6"
3 1/2	6 5/8"	7"
4	7"	8"
4 1/2	7 3/4"	9"
5	8 5/8"	10"
5 1/2	9 1/2"	11"
6	10 5/8"	12"
6 1/2	11 1/4"	13"
7	12 1/8"	14"
7 1/2	13"	15"
8	13 3/8"	16"
8 1/2	14 3/4"	17"
9	15 5/8"	18"
9 1/2	16 1/2"	19"
10	17 5/8"	20"
10 1/2	18 1/8"	21"
11	19"	22"
11 1/2	19 5/8"	23"

Spacing In.	Jack Rafter Length
1	1 1/4"
2	3 1/2"
3	5 1/4"
4	6 7/8"
5	8 5/8"
6	10 3/8"
7	1' 0 1/8"
8	1' 1 1/8"
9	1' 3 3/8"
10	1' 5 3/8"
11	1' 7 1/8"
12	1' 8 3/4"
13	1' 10 1/2"
14	2' 0 1/4"
15	2' 2"
16	2' 3 3/4"
17	2' 5 1/2"
18	2' 7 1/4"
19	2' 9"
20	2' 10 5/8"
21	3' 0 3/8"
22	3' 2 1/8"
23	3' 3 3/8"
24	3' 5 5/8"

Rafter Thickness	Miter Allowance for Hip and Valley Rafters	Rafter Depth	Bottom Allowance
1 1/2"	1 5/16"	3 1/2"	4 1/16"
1 5/8"	1 1/16"	5 1/2"	7 1/16"
1 3/4"	1 1/2"	7 1/4"	10 1/4"
1 7/8"	1 5/8"	9 1/4"	13 3/8"

18 INCH RISE 18-12 PITCH 56¼ DEGREES

Run Ft.	Common Rafter Length	Hip or Val. Rafter Length
1	1' 9 ⁵ / ₈ "	2' 0 ³ / ₄ "
2	3' 7 ¹ / ₄ "	4' 1 ¹ / ₂ "
3	5' 4 ⁷ / ₈ "	6' 2 ¹ / ₄ "
4	7' 2 ¹ / ₂ "	8' 3"
5	9' 0 ¹ / ₈ "	10' 3 ⁵ / ₈ "
6	10' 9 ³ / ₈ "	12' 4 ³ / ₈ "
7	12' 7 ³ / ₈ "	14' 5 ¹ / ₄ "
8	14' 5 ¹ / ₈ "	16' 5 ⁵ / ₈ "
9	16' 2 ³ / ₄ "	18' 6 ⁵ / ₈ "
10	18' 0 ³ / ₈ "	20' 7 ³ / ₈ "
11	19' 10"	22' 8 ¹ / ₈ "
12	21' 7 ⁵ / ₈ "	24' 8 ⁵ / ₈ "
13	23' 5 ¹ / ₄ "	26' 9 ⁵ / ₈ "
14	25' 2 ¹ / ₈ "	28' 10 ³ / ₈ "
15	27' 0 ¹ / ₂ "	30' 11 ¹ / ₈ "
16	28' 10 ¹ / ₈ "	32' 11 ¹ / ₈ "
17	30' 7 ¹ / ₄ "	35' 0 ¹ / ₂ "
18	32' 5 ³ / ₈ "	37' 1 ¹ / ₄ "
19	34' 3"	39' 2"
20	36' 0 ³ / ₈ "	41' 2 ³ / ₄ "
21	37' 10 ¹ / ₄ "	43' 3 ¹ / ₂ "
22	39' 7 ⁵ / ₈ "	45' 4 ¹ / ₄ "
23	41' 5 ⁵ / ₈ "	47' 5"
24	43' 3 ¹ / ₄ "	49' 5 ³ / ₄ "
25	45' 0 ³ / ₈ "	51' 6 ¹ / ₂ "

Run In.	Common Rafter Length	Hip or Val. Rafter Length
½	¾"	1"
1	1¾"	2"
1½	2¾"	3½"
2	3¾"	4½"
2½	4½"	5½"
3	5¾"	6½"
3½	6¾"	7¾"
4	7¾"	8¾"
4½	8½"	9¾"
5	9"	10¾"
5½	9¾"	11¾"
6	10¾"	12¾"
6½	11¾"	13¾"
7	12¾"	14¾"
7½	13¾"	15½"
8	14½"	16½"
8 ½	15¾"	17½"
9	16¼"	18½"
9½	17¾"	1¾"
10	18 ½"	20¾"
10½	19"	21¾"
11	19¾"	22¾"
11½	20¾"	23¾"

Spacing In.	Jack Rafter Length
1	1¾"
2	3¾"
3	5¾"
4	7¾"
5	9"
6	10¾"
7	1' 0 ³ / ₈ "
8	1' 2 ³ / ₈ "
9	1' 4 ¹ / ₄ "
10	1' 6"
11	1' 7 ⁵ / ₈ "
12	1' 9 ³ / ₈ "
13	1' 11½"
14	2' 1¼"
15	2' 3"
16	2' 4¾"
17	2' 6 ⁵ / ₈ "
18	2' 8½"
19	2' 10¼"
20	3' 0"
21	3' 1 ¹ / ₈ "
22	3' 3 ³ / ₈ "
23	3' 5½"
24	3' 7¼"

Rafter Thickness	Miter Allowance for Hip and Valley Rafters	Rafter Depth	Bottom Allowance
1½"	1¾"	3½"	5¼"
1¾"	1 ¹ / ₁₆ "	5½"	8¼"
1¾"	1 ¹ / ₁₆ "	7¼"	10 ³ / ₈ "
1¾"	1 ¹ / ₁₆ "	9¼"	13 ³ / ₈ "

19 INCH RISE 19-12 PITCH 57³/₄ DEGREES

Run Ft.	Common Rafter Length	Hip or Val. Rafter Length
1	1' 10 ¹ / ₂ "	2' 1 ¹ / ₂ "
2	3' 9"	4' 3"
3	5' 7 ³ / ₈ "	6' 4 ³ / ₈ "
4	7' 5 ⁵ / ₈ "	8' 5 ⁵ / ₈ "
5	9' 4 ³ / ₈ "	10' 7 ³ / ₈ "
6	11' 2 ⁷ / ₈ "	12' 8 ⁷ / ₈ "
7	13' 1 ¹ / ₄ "	14' 10 ³ / ₈ "
8	14' 11 ³ / ₄ "	16' 11 ³ / ₄ "
9	16' 10 ¹ / ₄ "	19' 1 ¹ / ₄ "
10	18' 8 ³ / ₄ "	21' 2 ³ / ₄ "
11	20' 7 ¹ / ₄ "	23' 4 ¹ / ₄ "
12	22' 5 ⁵ / ₈ "	25' 5 ³ / ₄ "
13	24' 4 ¹ / ₈ "	27' 7 ¹ / ₈ "
14	26' 2 ⁵ / ₈ "	29' 8 ⁵ / ₈ "
15	28' 1 ¹ / ₈ "	31' 10 ¹ / ₈ "
16	29' 11 ¹ / ₂ "	33' 11 ⁵ / ₈ "
17	31' 10"	36' 1 ¹ / ₈ "
18	33' 8 ¹ / ₂ "	38' 2 ¹ / ₂ "
19	35' 7"	40' 4"
20	37' 5 ¹ / ₂ "	42' 5 ¹ / ₂ "
21	39' 3 ⁵ / ₈ "	44' 7"
22	41' 2 ³ / ₈ "	46' 8 ¹ / ₂ "
23	43' 0 ⁷ / ₈ "	48' 9 ⁷ / ₈ "
24	44' 11 ³ / ₈ "	50' 11 ³ / ₈ "
25	46' 9 ³ / ₄ "	53' 0 ⁷ / ₈ "

Run In.	Common Rafter Length	Hip or Val. Rafter Length
1/2	7/8"	1"
1	1 1/8"	2 1/8"
1 1/2	2 3/4"	3 3/8"
2	3 3/4"	4 1/4"
2 1/2	4 5/8"	5 1/4"
3	5 5/8"	6 3/8"
3 1/2	6 1/2"	7 3/8"
4	7 1/2"	8 1/2"
4 1/2	8 3/8"	9 1/2"
5	9 3/8"	10 5/8"
5 1/2	10 1/4"	11 5/8"
6	11 1/4"	12 3/4"
6 1/2	12 1/8"	13 3/4"
7	13 3/8"	14 7/8"
7 1/2	14"	15 5/8"
8	15"	17"
8 1/2	15 5/8"	18"
9	16 3/8"	19 3/8"
9 1/2	17 1/4"	20 1/8"
10	18 3/4"	21 1/4"
10 1/2	19 5/8"	22 1/4"
11	20 5/8"	23 3/8"
11 1/2	21 1/2"	24 3/8"

Spacing In.	Jack Rafter Length
1	1 7/8"
2	3 3/4"
3	5 5/8"
4	7 1/2"
5	9 3/8"
6	11 1/4"
7	1' 1 1/8"
8	1' 3"
9	1' 4 3/8"
10	1' 6 3/4"
11	1' 8 5/8"
12	1' 10 1/2"
13	2' 0 3/8"
14	2' 2 1/4"
15	2' 4 1/8"
16	2' 6"
17	2' 7 7/8"
18	2' 9 3/4"
19	2' 11 5/8"
20	3' 1 1/2"
21	3' 3 3/8"
22	3' 5 1/4"
23	3' 7 1/8"
24	3' 9"

Rafter Thickness	Miter Allowance for Hip and Valley Rafters	Rafter Depth	Bottom Allowance
1 1/2"	1 3/8"	3 1/2"	5 9/16"
1 5/8"	1 1/2"	5 1/2"	8 11/16"
1 3/4"	1 5/8"	7 1/4"	11 1/2"
1 7/8"	1 3/4"	9 1/4"	14 5/8"

20 INCH RISE 20-12 PITCH 59 DEGREES

Run Ft.	Common Rafter Length	Hip or Val. Rafter Length
1	1' 11 $\frac{3}{8}$ "	2' 2 $\frac{1}{4}$ "
2	3' 10 $\frac{5}{8}$ "	4' 4 $\frac{1}{2}$ "
3	5' 10"	6' 6 $\frac{3}{4}$ "
4	7' 9 $\frac{1}{4}$ "	8' 8 $\frac{1}{8}$ "
5	9' 8 $\frac{5}{8}$ "	10' 11 $\frac{1}{8}$ "
6	11' 8"	13' 1 $\frac{3}{8}$ "
7	13' 7 $\frac{1}{4}$ "	15' 3 $\frac{5}{8}$ "
8	15' 6 $\frac{5}{8}$ "	17' 5 $\frac{7}{8}$ "
9	17' 5 $\frac{7}{8}$ "	19' 8 $\frac{1}{8}$ "
10	19' 5 $\frac{1}{4}$ "	21' 10 $\frac{1}{4}$ "
11	21' 4 $\frac{1}{2}$ "	24' 0 $\frac{1}{2}$ "
12	23' 3 $\frac{7}{8}$ "	26' 2 $\frac{3}{4}$ "
13	25' 3 $\frac{1}{4}$ "	28' 5"
14	27' 2 $\frac{1}{2}$ "	30' 7 $\frac{1}{4}$ "
15	29' 1 $\frac{1}{8}$ "	32' 9 $\frac{1}{2}$ "
16	31' 1 $\frac{1}{8}$ "	34' 11 $\frac{1}{8}$ "
17	33' 0 $\frac{1}{2}$ "	37' 1 $\frac{3}{8}$ "
18	34' 11 $\frac{1}{8}$ "	39' 4 $\frac{1}{8}$ "
19	36' 11 $\frac{1}{8}$ "	41' 6 $\frac{3}{8}$ "
20	38' 10 $\frac{1}{2}$ "	43' 8 $\frac{5}{8}$ "
21	40' 9 $\frac{3}{4}$ "	45' 10 $\frac{7}{8}$ "
22	42' 9 $\frac{1}{8}$ "	48' 1"
23	44' 8 $\frac{1}{2}$ "	50' 3 $\frac{1}{4}$ "
24	46' 7 $\frac{3}{4}$ "	52' 5 $\frac{1}{2}$ "
25	48' 7 $\frac{1}{8}$ "	54' 7 $\frac{3}{4}$ "

Run In.	Common Rafter Length	Hip or Val. Rafter Length
$\frac{1}{2}$	1"	1 $\frac{1}{8}$ "
1	2"	2 $\frac{1}{8}$ "
1 $\frac{1}{2}$	2 $\frac{1}{2}$ "	3 $\frac{1}{4}$ "
2	3 $\frac{1}{8}$ "	4 $\frac{3}{8}$ "
2 $\frac{1}{2}$	4 $\frac{1}{8}$ "	5 $\frac{1}{2}$ "
3	5 $\frac{1}{8}$ "	6 $\frac{1}{2}$ "
3 $\frac{1}{2}$	6 $\frac{1}{4}$ "	7 $\frac{5}{8}$ "
4	7 $\frac{1}{4}$ "	8 $\frac{3}{4}$ "
4 $\frac{1}{2}$	8 $\frac{1}{4}$ "	9 $\frac{5}{8}$ "
5	9 $\frac{1}{4}$ "	10 $\frac{7}{8}$ "
5 $\frac{1}{2}$	10 $\frac{1}{4}$ "	12"
6	11 $\frac{1}{8}$ "	13 $\frac{1}{8}$ "
6 $\frac{1}{2}$	12 $\frac{1}{8}$ "	14 $\frac{1}{4}$ "
7	13 $\frac{3}{8}$ "	15 $\frac{1}{4}$ "
7 $\frac{1}{2}$	14 $\frac{1}{2}$ "	16 $\frac{3}{8}$ "
8	15 $\frac{1}{2}$ "	17 $\frac{1}{2}$ "
8 $\frac{1}{2}$	16 $\frac{1}{2}$ "	18 $\frac{5}{8}$ "
9	17 $\frac{1}{2}$ "	19 $\frac{7}{8}$ "
9 $\frac{1}{2}$	18 $\frac{5}{8}$ "	20 $\frac{3}{4}$ "
10	19 $\frac{7}{8}$ "	21 $\frac{1}{8}$ "
10 $\frac{1}{2}$	20 $\frac{7}{8}$ "	23"
11	21 $\frac{7}{8}$ "	24"
11 $\frac{1}{2}$	22 $\frac{3}{8}$ "	25 $\frac{1}{8}$ "

Spacing In.	Jack Rafter Length
1	2"
2	3 $\frac{3}{8}$ "
3	5 $\frac{1}{8}$ "
4	7 $\frac{1}{4}$ "
5	9 $\frac{1}{4}$ "
6	11 $\frac{1}{8}$ "
7	1' 1 $\frac{1}{8}$ "
8	1' 3 $\frac{1}{2}$ "
9	1' 5 $\frac{1}{2}$ "
10	1' 7 $\frac{3}{8}$ "
11	1' 9 $\frac{3}{8}$ "
12	1' 11 $\frac{1}{8}$ "
13	2' 1 $\frac{1}{4}$ "
14	2' 3 $\frac{1}{4}$ "
15	2' 5 $\frac{1}{8}$ "
16	2' 7 $\frac{1}{8}$ "
17	2' 9"
18	2' 11"
19	3' 0 $\frac{1}{8}$ "
20	3' 2 $\frac{1}{8}$ "
21	3' 4 $\frac{1}{8}$ "
22	3' 6 $\frac{3}{4}$ "
23	3' 8 $\frac{3}{4}$ "
24	3' 10 $\frac{1}{8}$ "

Rafter Thickness	Miter Allowance for Hip and Valley Rafters	Rafter Depth	Bottom Allowance
1 $\frac{1}{2}$ "	1 $\frac{1}{16}$ "	3 $\frac{1}{2}$ "	5 $\frac{3}{16}$ "
1 $\frac{5}{8}$ "	1 $\frac{1}{16}$ "	5 $\frac{1}{2}$ "	9 $\frac{3}{16}$ "
1 $\frac{3}{4}$ "	1 $\frac{11}{16}$ "	7 $\frac{1}{4}$ "	12 $\frac{1}{16}$ "
1 $\frac{7}{8}$ "	1 $\frac{13}{16}$ "	9 $\frac{1}{4}$ "	15 $\frac{1}{16}$ "

21 INCH RISE 21-12 PITCH 60¼ DEGREES

Run Ft.	Common Rafter Length	Hip or Val. Rafter Length
1	2' 0 ¹ / ₈ "	2' 3"
2	4' 0 ³ / ₈ "	4' 6"
3	6' 0 ¹ / ₂ "	6' 9"
4	8' 0 ³ / ₄ "	9' 0"
5	10' 0 ¹ / ₂ "	11' 3"
6	12' 1 ¹ / ₈ "	13' 6"
7	14' 1 ¹ / ₄ "	15' 9"
8	16' 1 ¹ / ₂ "	18' 0"
9	18' 1 ⁵ / ₈ "	20' 3"
10	20' 1 ¹ / ₈ "	22' 6"
11	22' 2"	24' 9"
12	24' 2 ¹ / ₄ "	27' 0"
13	26' 2 ³ / ₈ "	29' 3"
14	28' 2 ⁵ / ₈ "	31' 6"
15	30' 2 ³ / ₄ "	33' 9"
16	32' 3"	36' 0"
17	34' 3 ¹ / ₈ "	38' 3"
18	36' 3 ³ / ₈ "	40' 6"
19	38' 3 ¹ / ₂ "	42' 9"
20	40' 3 ³ / ₄ "	45' 0"
21	42' 3 ⁵ / ₈ "	47' 3"
22	44' 4 ¹ / ₈ "	49' 6"
23	46' 4 ¹ / ₄ "	51' 9"
24	48' 4 ¹ / ₂ "	54' 0"
25	50' 4 ⁵ / ₈ "	56' 3"

Run In.	Common Rafter Length	Hip or Val. Rafter Length
½	1"	1 ¹ / ₈ "
1	2"	2 ¹ / ₄ "
1½	3"	3 ³ / ₈ "
2	4"	4 ¹ / ₂ "
2½	5"	5 ⁵ / ₈ "
3	6"	6 ³ / ₄ "
3½	7"	7 ¹ / ₈ "
4	8 ¹ / ₈ "	8 ³ / ₄ "
4½	9 ¹ / ₈ "	9"
5	10 ¹ / ₈ "	10 ¹ / ₈ "
5½	11 ¹ / ₈ "	11 ¹ / ₄ "
6	12 ¹ / ₈ "	12 ³ / ₈ "
6½	13 ¹ / ₈ "	13 ¹ / ₂ "
7	14 ¹ / ₈ "	14 ⁵ / ₈ "
7½	15 ¹ / ₈ "	15 ³ / ₄ "
8	16 ¹ / ₈ "	16 ¹ / ₈ "
8½	17 ¹ / ₈ "	18"
9	18 ¹ / ₈ "	19 ¹ / ₈ "
9½	19 ¹ / ₈ "	20 ¹ / ₄ "
10	20 ¹ / ₄ "	21 ¹ / ₈ "
10½	21 ¹ / ₄ "	21 ³ / ₈ "
11	22 ¹ / ₄ "	22 ¹ / ₂ "
11½	23 ¹ / ₄ "	23 ³ / ₈ "

Spacing In.	Jack Rafter Length
1	2"
2	4"
3	6"
4	8 ¹ / ₈ "
5	10 ¹ / ₈ "
6	1' 0 ¹ / ₈ "
7	1' 2 ¹ / ₈ "
8	1' 4 ¹ / ₈ "
9	1' 6 ¹ / ₈ "
10	1' 8 ¹ / ₈ "
11	1' 10 ¹ / ₈ "
12	2' 0 ¹ / ₄ "
13	2' 2 ¹ / ₄ "
14	2' 4 ¹ / ₄ "
15	2' 6 ¹ / ₄ "
16	2' 8 ¹ / ₄ "
17	2' 10 ¹ / ₄ "
18	3' 0 ¹ / ₄ "
19	3' 2 ¹ / ₄ "
20	3' 4 ³ / ₈ "
21	3' 6 ³ / ₈ "
22	3' 8 ³ / ₈ "
23	3' 10 ³ / ₈ "
24	4' 0 ³ / ₈ "

Rafter Thickness	Miter Allowance for Hip and Valley Rafters	Rafter Depth	Bottom Allowance
1½"	1½"	3½"	6 ¹ / ₈ "
1 ⁵ / ₈ "	1 ⁵ / ₈ "	5½"	9 ⁵ / ₈ "
1¾"	1¾"	7¼"	12 ¹¹ / ₁₆ "
1 ⁷ / ₈ "	1 ⁷ / ₈ "	9¼"	16 ³ / ₁₆ "

22 INCH RISE 22-12 PITCH 61½ DEGREES

Run Ft.	Common Rafter Length	Hip or Val. Rafter Length
1	2' 1"	2' 3¼"
2	4' 2½"	4' 7½"
3	6' 3½"	6' 11¾"
4	8' 4¼"	9' 3½"
5	10' 5¼"	11' 6¾"
6	12' 6¾"	13' 10¾"
7	14' 7¾"	16' 2½"
8	16' 8½"	18' 6¼"
9	18' 9½"	20' 10½"
10	20' 10½"	23' 1½"
11	22' 11½"	25' 5½"
12	25' 0¾"	27' 9¾"
13	27' 1¾"	30' 1¼"
14	29' 2½"	32' 5"
15	31' 3½"	34' 8¾"
16	33' 5"	37' 0½"
17	35' 6"	39' 4¾"
18	37' 7 ⅛"	41' 8 ⅛"
19	39' 8½"	43' 11½"
20	41' 9¼"	46' 3¾"
21	43' 10¼"	48' 7½"
22	45' 11½"	50' 11¼"
23	48' 0 ¾"	53' 3"
24	50' 1½"	55' 6¾"
25	52' 2½"	57' 10½"

Run In.	Common Rafter Length	Hip or Val. Rafter Length
½	1"	1⅞"
1	2½"	2¾"
1½	3½"	3½"
2	4½"	4½"
2½	5¼"	5¾"
3	6¼"	7"
3½	7¼"	8½"
4	8¾"	9¼"
4½	9¾"	10¾"
5	10½"	11½"
5½	11½"	12¾"
6	12½"	13¾"
6½	13½"	15"
7	14½"	16¼"
7½	15½"	17¾"
8	16¾"	18½"
8½	17¾"	19¾"
9	18¾"	20¾"
9½	19¾"	22"
10	20¾"	23¾"
10½	21¾"	24¼"
11	23"	25 ½"
11½	24"	26¾"

Spacing In.	Jack Rafter Length
1	2⅞"
2	4½"
3	6¼"
4	8½"
5	10½"
6	1' 0½"
7	1' 2½"
8	1' 4¾"
9	1' 6¾"
10	1' 8½"
11	1' 11"
12	2' 1"
13	2' 3½"
14	2' 5¼"
15	2' 7¾"
16	2' 9¾"
17	2' 11½"
18	3' 1½"
19	3' 3¾"
20	3' 5¼"
21	3' 7½"
22	3' 10"
23	4' 0"
24	4' 2½"

Rafter Thickness	Miter Allowance for Hip and Valley Rafters	Rafter Depth	Bottom Allowance
1½"	1⅞"	3½"	6⅞"
1⅞"	1⅞"	5½"	10⅞"
1¾"	1⅞"	7¼"	13⅞"
1⅞"	1⅞"	9¼"	16⅞"

23 INCH RISE 23-12 PITCH 62½ DEGREES

Run Ft.	Common Rafter Length	Hip or Val. Rafter Length
1	2' 2"	2' 4½"
2	4' 3⅝"	4' 9⅝"
3	6' 5⅝"	7' 1¾"
4	8' 7¾"	9' 6⅝"
5	10' 9¾"	11' 10⅝"
6	12' 11⅝"	14' 3½"
7	15' 1⅝"	16' 8⅝"
8	17' 3½"	19' 0⅝"
9	19' 5½"	21' 5¼"
10	21' 7⅝"	23' 9⅝"
11	23' 9⅝"	26' 2⅝"
12	25' 11¼"	28' 7"
13	28' 1¼"	30' 11⅝"
14	30' 3¼"	33' 4⅝"
15	32' 5⅝"	35' 8¾"
16	34' 7⅝"	38' 1⅝"
17	36' 9"	40' 5⅝"
18	38' 11"	42' 10½"
19	41' 0⅝"	45' 3⅝"
20	43' 2⅝"	47' 7⅝"
21	45' 4¾"	50' 0¼"
22	47' 6¾"	52' 4⅝"
23	49' 8⅝"	54' 9⅝"
24	51' 10⅝"	57' 2"
25	54' 0½"	59' 6⅝"

Run In.	Common Rafter Length	Hip or Val. Rafter Length
½	1⅝"	1¼"
1	2⅝"	2⅝"
1½	3¼"	3⅝"
2	4⅝"	4¾"
2½	5⅝"	6"
3	6½"	7⅝"
3½	7⅝"	8⅝"
4	8⅝"	9½"
4½	9¾"	10¾"
5	10¾"	12"
5½	11⅝"	13⅝"
6	13"	14¼"
6½	14⅝"	15½"
7	15⅝"	16⅝"
7½	16¼"	17⅝"
8	17⅝"	19"
8½	18⅝"	20¼"
9	19 ½"	21⅝"
9½	20⅝"	22⅝"
10	21⅝"	23¾"
10 ½	22 ¾"	25"
11	23¾"	26¼"
11½	24⅝"	27⅝"

Spacing In.	Jack Rafter Length
1	2¼"
2	4⅝"
3	6½"
4	8⅝"
5	10¾"
6	1' 1"
7	1' 3⅝"
8	1' 5¼"
9	1' 7½"
10	1' 9⅝"
11	1' 11¼"
12	2' 2"
13	2' 4⅝"
14	2' 6¼"
15	2' 8¾"
16	2' 10⅝"
17	3' 0¾"
18	3' 2⅝"
19	3' 5⅝"
20	3' 7¼"
21	3' 9⅝"
22	3' 11½"
23	4' 1¾"
24	4' 3⅝"

Rafter Thickness	Miter Allowance for Hip and Valley Rafters	Rafter Depth	Bottom Allowance
1½"	1⅝"	3½"	6⅛"
1⅝"	1¾"	5½"	10⅛"
1¾"	1⅝"	7¼"	13⅝"
1⅝"	2"	9¼"	17¾"

24 INCH RISE 24-12 PITCH 63½ DEGREES

Run Ft.	Common Rafter Length	Hip or Val. Rafter Length
1	2' 2½"	2' 5½"
2	4' 5½"	4' 10¾"
3	6' 8½"	7' 4½"
4	8' 11¾"	9' 9½"
5	11' 2½"	12' 3"
6	13' 5"	14' 8¾"
7	15' 7½"	17' 1¾"
8	17' 10½"	19' 7½"
9	20' 1½"	22' 0½"
10	22' 4¾"	24' 6"
11	24' 7½"	26' 11¾"
12	26' 10"	29' 4¾"
13	29' 0¾"	31' 10½"
14	31' 3¾"	34' 3½"
15	33' 6½"	36' 8½"
16	35' 9¾"	39' 2¼"
17	38' 0¾"	41' 7¼"
18	40' 3"	44' 1½"
19	42' 5¾"	46' 6½"
20	44' 8¾"	48' 11½"
21	46' 11½"	51' 5¼"
22	49' 2¾"	53' 10½"
23	51' 5½"	56' 4"
24	53' 8"	58' 9½"
25	55' 10½"	61' 2½"

Run In.	Common Rafter Length	Hip or Val. Rafter Length
½	1½"	1¼"
1	2¼"	2½"
1½	3¾"	3¾"
2	4½"	4¾"
2½	5½"	6½"
3	6¾"	7¾"
3½	7¾"	8¾"
4	9"	9¾"
4½	10"	11"
5	11½"	12¼"
5½	12¼"	13½"
6	13¾"	14¾"
6½	14½"	15¾"
7	15¾"	17½"
7½	16¾"	18¼"
8	17¾"	19½"
8½	19"	20¾"
9	20½"	22"
9½	21¼"	23¼"
10	22¾"	24¾"
10½	23¾"	25¾"
11	24½"	26½"
11½	25¾"	28½"

Spacing In.	Jack Rafter Length
1	2¼"
2	4½"
3	6¾"
4	9"
5	11½"
6	1' 1¾"
7	1' 3¾"
8	1' 5½"
9	1' 8½"
10	1' 10½"
11	2' 0½"
12	2' 2½"
13	2' 5½"
14	2' 7¼"
15	2' 9½"
16	2' 11¼"
17	3' 2"
18	3' 4¼"
19	3' 6½"
20	3' 8¾"
21	3' 11"
22	4' 1¼"
23	4' 3¾"
24	4' 5¾"

Rafter Thickness	Miter Allowance for Hip and Valley Rafters	Rafter Depth	Bottom Allowance
1½"	1 11/16"	3½"	7"
1¾"	1 13/16"	5½"	11"
1¾"	1 15/16"	7¼"	14½"
1¾"	2"	9¼"	18½"

**IRWIN® Rafter Square can also be used as a
Protractor, Saw Guide, and Tri & Miter Square**

**L'équerre de charpente IRWIN® peut également
être utilisée comme rapporteur d'angle, guide de
scie et équerre à épaulement et à onglet**

**La escuadra IRWIN® para vigas también se
puede emplear como protractor, guía de sierra
y como tri-escuadra de inglete.**

©2011

IRWIN
TOOLS

8935 NorthPointe Executive Drive
Huntersville, NC 28078 - U.S.A.
1-800-GO-IRWIN
www.irwin.com

C10110464